



*Operator's Manual
& Parts Drawings*

KP540

Power Rake

Europe C€ - Serial Number KP540-AB1178 --





500 Venture Drive
Orrville Oh 44667
www.ventrac.com

View all manuals



Visit ventrac.com/manuals for the latest version of this operator's manual.

A downloadable parts manual is also available.

To the Owner Contact Information and Product Identification

If you need to contact an authorized Ventrac dealer for information on servicing your product, always provide the product model and serial numbers.

Please fill in the following information for future reference. See the picture(s) below to find the location of the identification numbers. Record them in the spaces provided.

Date of Purchase: _____

Dealer: _____

Dealer Address: _____

Dealer Phone Number: _____

Dealer Fax Number: _____

<p>Model # (A): _____</p> <p>Serial # (B): _____</p> <p style="text-align: center;">Affix Part/Serial Number label here.</p>
--

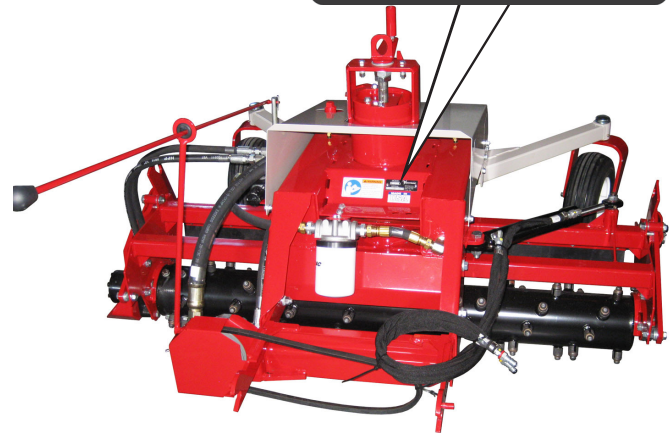

Venture Products Inc. reserves the right to make changes in design or specifications without obligation to make like changes on previously manufactured products.

TABLE OF CONTENTS

INTRODUCTION	PAGE 5
Product Description.....	5
Why Do I Need an Operator’s Manual?	5
Using Your Manual	6
Manual Glossary	6
SAFETY	PAGE 7
Safety Decals	7
General Safety Procedures.....	9
Training Required.....	9
Personal Protective Equipment Requirements	9
Operation Safety	9
Preventing Accidents.....	10
Keep Riders Off.....	10
Operating On Slopes.....	11
Roadway Safety	11
Truck Or Trailer Transport	11
Maintenance.....	12
Fuel Safety	12
Hydraulic Safety	13
OPERATIONAL CONTROLS	PAGE 15
Height Adjustment Crank	15
Valve Control Rod (Drum Rotation Valve).....	15
Rotor Angle	15
GENERAL OPERATION	PAGE 16
Daily Inspection.....	16
Attaching	16
Detaching	16
Leveling Work Area Prior to Finish Grading	17
Spreading Fill or Topsoil.....	17
Debris Removal.....	17
Finish Grading (Lawn Preparation)	17
Gravel Driveway Restoration	17
Driveway Finish.....	18
Gravel Paths & Walkways.....	18
Chemical Free Weeding.....	18
Operating Procedure.....	18
Cleaning Debris From Rake Drum.....	19
Transport of Power Rake	19
Setting Rake Drum Depth	19
Dirt Flap.....	19

TABLE OF CONTENTS

SERVICE	PAGE 20
Cleaning and General Maintenance.....	20
Drive Belt Inspection	20
Drive Belt Replacement	20
Tire Pressure.....	20
Carbide Tip Replacement.....	20
Checking Hydraulic Oil Level	20
Changing Hydraulic Oil & Filter	21
Power Rake Frame Leveling.....	21
Lubrication Locations	22
Storage.....	22
Maintenance Schedule.....	23
Maintenance Checklist	23
SPECIFICATIONS	PAGE 24
Dimensions	24
Features	24
Noise Emissions.....	25
EC Declaration of Conformity.....	25
PARTS	PAGE 26
Hydraulic Diagram & O-Ring Chart.....	26
Main Frame, Hitch Frame, & Filter	28
Hydraulic Pump, Valve, & Shift Handle	30
Rotor Frame, Rotor, & Motor.....	32
Height Adjuster.....	34
Wheel Frame & Shields	36
Side Wings, Dirt Flap, & Hydraulic Power Angle.....	38
WARRANTY	PAGE 40

INTRODUCTION



Venture Products Inc. is pleased to provide you with your new Ventrac KP540 power rake! We hope that Ventrac equipment will provide you with a ONE Tractor Solution.

Product Description

The KP540 power rake is designed for smoothing rough ground, removing surface rocks and debris, preparing soil for new lawn installations, leveling gravel driveways, and weeding gravel parking lots, driveways, and walking paths. Its compact design allows the operator to work in tight quarters, including around corners and edges.

Seventy-two replaceable carbide tips pulverize and refine the soil. Materials can be moved forward or to either side by hydraulically angling the drum left or right. The drum can also be reversed to allow back-dragging of soils to pull material away from buildings, trees, or other obstructions. A rotating handle raises or lowers the rotor in 1/8th inch (3.2 mm) increments with 3-1/2 inches (89 mm) of travel.

Adjustable side wings can be lowered on either side for routing material.

Why Do I Need an Operator's Manual?

This manual has been created to help you gain the important knowledge of what is needed to safely operate, maintain, and service your machine. It is divided into sections for convenient reference of the appropriate section.

You must read and understand the operator's manual for each piece of Ventrac equipment you own. Reading the operator's manual will help you become familiar with each specific piece of equipment. Understanding the operator's manual will help you, as well as others, avoid personal injury and/or damage to the equipment. Keep this manual with the machine at all times. The manual should remain with the machine even if it is sold. If this manual becomes damaged or unreadable, it should be replaced immediately. Contact your local Ventrac dealer for a replacement.

When using a Ventrac attachment, be sure to read and follow the safety and operating instructions of both the power unit and the attachment being used to ensure the safest operation possible.

The information in this manual provides the operator with the safest procedures to operate the machine while getting the maximum use out of the unit. Failure to follow the safety precautions listed in this manual may result in personal injury and/or damage to the equipment.

INTRODUCTION

Using Your Manual

Throughout this manual, you will encounter special messages and symbols that identify potential safety concerns to help you as well as others avoid personal injury or damage to the equipment.

SYMBOL DEFINITIONS



ATTENTION

This symbol identifies potential health and safety hazards. It marks safety precautions. Your safety and the safety of others is involved.

There are three signal words that describe the level of safety concern: Danger, Warning, and Caution. Safety should always be the #1 priority when working on or operating equipment. Accidents are more likely to occur when proper operating procedures are not followed or inexperienced operators are involved.

Note: Right-Hand and Left-Hand orientations may be referred to at different places throughout this manual. Right-Hand and Left-Hand is determined as if sitting on the power unit seat facing forward.

SIGNAL WORD DEFINITIONS

⚠ DANGER

Indicates an imminently hazardous situation which, if not avoided, will result in death or serious injury. This signal word is limited to the most extreme cases.

⚠ WARNING

Indicates a potentially hazardous situation which, if not avoided, could result in death or serious injury.

⚠ CAUTION

Indicates a potentially hazardous situation which, if not avoided, may result in minor or moderate injury and/or property damage. It may also be used to alert against unsafe practices.

Manual Glossary

Power Unit A Ventrac tractor or other Ventrac engine powered device that may be operated by itself or with an attachment or accessory.

Attachment A piece of Ventrac equipment that requires a Power Unit for operation.

Accessory A device that attaches to a Power Unit or Attachment to extend its capabilities.

Machine Describes any "Attachment" or "Accessory" that is used in conjunction with a power unit.

SAFETY

Safety Decals

The following safety decals must be maintained on your KP540 power rake.

Keep all safety decals legible. Remove all grease, dirt, and debris from safety decals and instructional labels. If any decals are faded, illegible, or missing, contact your dealer promptly for replacements.

When new components are installed, be sure that current safety decals are affixed to the replacement components.



SAFETY

A

⚠ **DANGER**



To prevent serious injury or death from pinching:

- **Keep all persons and objects clear while any part of this machine is in motion.**

00.0102

B

⚠ **WARNING**





HIGH-PRESSURE FLUID HAZARD

To prevent serious injury or death:

- Relieve pressure on system before repairing or adjusting or disconnecting.
- Wear proper hand and eye protection when searching for leaks. Use wood or cardboard instead of hands.
- Keep all components in good repair

00.0103

C



⚠ **WARNING**

Read and understand operator's manual before using this machine.

Failure to follow operating instructions could result in death or serious injury.

PART NO. 00.0217

Decal	Description	Part Number	Quantity
A	Danger, Pinching Hazard	00.0102	2
B	Warning, High Pressure Fluid Hazard	00.0103	1
C	Warning, Read Owner's Manual	00.0217	1

SAFETY



General Safety Procedures for Ventrac Power Units, Attachments, & Accessories



Training Required

- The owner of this machine is solely responsible for properly training the operators.
- The owner/operator is solely responsible for the operation of this machine and prevention of accidents or injuries occurring to him/herself, other people, or property.
- Do not allow operation or service by children or untrained personnel. Local regulations may restrict the age of the operator.
- Before operating this machine, read the operator's manual and understand its contents.
- If the operator of the machine cannot understand this manual, then it is the responsibility of this machine's owner to fully explain the material within this manual to the operator.
- Learn and understand the use of all controls.
- Know how to stop the power unit and all attachments quickly in the event of an emergency.



Personal Protective Equipment Requirements

It is the responsibility of the owner to be sure that the operators use the proper personal protective equipment while operating the machine. Required personal protective equipment includes, but is not limited to, the following list.



- Wear a certified ear protection device to prevent loss of hearing.
- Prevent eye injury by wearing safety glasses while operating the machine.
- Closed toe shoes must be worn at all times.
- Long pants must be worn at all times.
- When operating in dusty conditions, it is recommended that a dust mask be worn.

Operation Safety

- Inspect machine before operation. Repair or replace any damaged, worn, or missing parts. Be sure guards and shields are in proper working condition and are secured in place. Make all necessary adjustments before operating machine.
- Some pictures in this manual may show shields or covers opened or removed in order to clearly illustrate any instructions. Under no circumstance should the machine be operated without these devices in place.
- Alterations or modifications to this machine can reduce safety and could cause damage to the machine. Do not alter safety devices or operate with shields or covers removed.
- Before each use, verify that all controls function properly and inspect all safety devices. Do not operate if controls or safety devices are not in proper working condition.
- Check parking brake function before operating. Repair or adjust parking brake if necessary.
- Observe and follow all safety decals.
- All controls are to be operated from the operator's station only.
- Always wear a seat belt if the machine has a roll cage/bar installed and in upright position.
- Ensure the attachment or accessory is locked or fastened securely to the power unit before operating.
- Ensure that all bystanders are clear of the power unit and attachment before operating. Stop machine if someone enters your work area.
- Always be alert to what is happening around you, but do not lose focus on the task you are performing. Always look in the direction the machine is moving.
- Look behind and down before backing up to be sure of a clear path.
- If you hit an object, stop and inspect the machine. Make all necessary repairs before operating machine again.
- Stop operation immediately at any sign of equipment failure. An unusual noise can be a warning of equipment failure or a sign that maintenance is required. Make all necessary repairs before operating machine again.

SAFETY



General Safety Procedures for Ventrac Power Units, Attachments, & Accessories



Operation Safety (continued)

- If equipped with a high/low range feature, never shift between high and low range while on a slope. Always move the machine to level ground and engage the parking brake before shifting range.
- Do not leave machine unattended while it is running.
- Always park the machine on level ground.
- Always shut off engine when connecting attachment drive belt to the power unit.
- Never leave the operator's station without lowering the attachment to the ground, setting the parking brake, shutting off the engine, and removing the ignition key. Make sure all moving parts have come to a complete stop before dismounting.
- Never leave equipment unattended without lowering the attachment to the ground, setting the parking brake, shutting off the engine, and removing the ignition key.
- Only operate in well-lit conditions.
- Do not operate when there is a risk of lightning.
- Never direct the discharge of any attachment in the direction of people, buildings, animals, vehicles, or other objects of value.
- Never discharge material against a wall or obstruction. Material may ricochet back towards the operator.
- Use extra caution when approaching blind corners, shrubs, trees, or other objects that may obscure vision.
- Do not run the engine in a building without adequate ventilation.
- Do not touch the engine or the muffler while the engine is running or immediately after stopping the engine. These areas may be hot enough to cause a burn.
- Do not change the engine governor settings or over-speed the engine. Operating engine at excessive speed may increase the hazard of personal injury.
- To reduce the hazard of fire, keep the battery compartment, engine, and muffler areas free of grass, leaves, excessive grease, and other flammable materials.

Preventing Accidents



- Clear working area of objects that might be hit or thrown from machine.
- Keep people and pets out of working area.
- Know the work area well before operation. Do not operate where traction or stability is questionable.
- Reduce speed when you are operating over rough ground.
- Equipment can cause serious injury and/or death when improperly used. Before operating, know and understand the operation and safety of the power unit and the attachment being used.

- Do not operate machine if you are not in good physical and mental health, if you will be distracted by personal devices, or are under the influence of any substance which might impair decision, dexterity, or judgment.
- Children are attracted to machine activity. Be aware of children and do not allow them in the working area. Turn off the machine if a child enters the work area.

Keep Riders Off

- Only allow the operator on the power unit. Keep riders off.
- Never allow riders on any attachment or accessory.

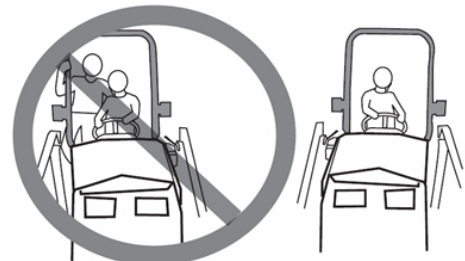

SAFETY



General Safety Procedures for Ventrac Power Units, Attachments, & Accessories



Operating On Slopes

- Slopes can cause loss-of-control and tip-over accidents, which can result in severe injury or death. Be familiar with the emergency parking brake, along with the power unit controls and their functions.
- If power unit is equipped with a fold down roll bar, it must be locked in the upright position when operating on any slope.
- Use low range (if equipped) when operating on slopes greater than 15 degrees.
- Do not stop or start suddenly when operating on slopes.
- Never shift between high and low range while on a slope. Always move the power unit to level ground and engage the parking brake before shifting range or placing the power unit in neutral.
- Variables such as wet surface and loose ground will reduce the degree of safety. Do not drive where machine could lose traction or tip over.
- Keep alert for hidden hazards in the terrain.
- Stay away from drop-offs, ditches, and embankments.
- Sharp turns should be avoided when operating on slopes.
- Pulling loads on hills decreases safety. It is the responsibility of the owner/operator to determine loads that can safely be controlled on slopes.
- Transport machine with attachment lowered or close to the ground to improve stability.
- While operating on slopes, drive in an up and down direction when possible. If turning is necessary while driving across slopes, reduce speed and turn slowly in the downhill direction.
- Assure a sufficient supply of fuel for continuous operation. A minimum of one-half tank of fuel is recommended.

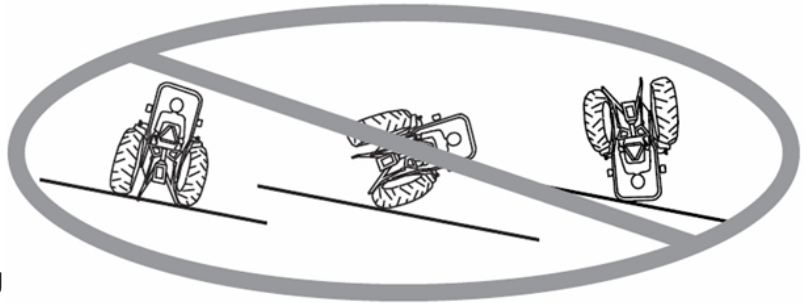

Roadway Safety

- Operate with safety lights when operating on or near roadways.
- Obey all state and local laws concerning operation on roadways.
- Slow down and be careful of traffic when operating near or crossing roadways. Stop before crossing roads or sidewalks. Use care when approaching areas or objects that may obscure vision.
- If there is doubt of safety conditions, discontinue machine operation until a time when operation can be performed safely.
- When operating near or on roadways, have a Slow Moving Vehicle Emblem clearly displayed.

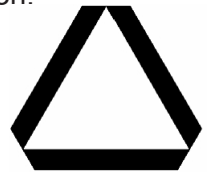

Truck Or Trailer Transport

- Use care when loading or unloading machine into a truck or trailer.
- Use full width ramps for loading machine into a truck or trailer.
- The parking brake is not sufficient to lock the machine during transport. Always secure the power unit and/or attachment to the transporting vehicle securely using straps, chains, cable, or ropes. Both front and rear straps should be directed down and outward from the machine.
- Shut off fuel supply to power unit during transport on truck or trailer.
- If equipped, turn the battery disconnect switch to the Off position to shut off electrical power.

SAFETY



General Safety Procedures for Ventrac Power Units, Attachments, & Accessories



Maintenance

- Keep all safety decals legible. Remove all grease dirt, and debris from safety decals and instructional labels.
- If any decals are faded, illegible, or missing, contact your dealer promptly for replacements.
- When new components are installed, be sure that current safety decals are affixed to the replacement components.
- If any component requires replacement, use only original Ventrac replacement parts.
- Always turn the battery disconnect to the Off position or disconnect the battery before performing any repairs. Disconnect the negative terminal first and the positive terminal last. Reconnect the positive terminal first and the negative terminal last.
- Keep all bolts, nuts, screws, and other fasteners properly tightened.
- Always lower the attachment to the ground, engage parking brake, shut off engine, and remove the ignition key. Make sure all moving parts have come to a complete stop before cleaning, inspection, adjusting or repairing.
- If the power unit, attachment, or accessory requires repairs or adjustments not instructed in the operator's manual, the power unit, attachment, or accessory must be taken to an authorized Ventrac dealer for service.
- Never perform maintenance on the power unit and/or attachment if someone is in the operator's station.
- Always use protective glasses when handling the battery.
- Check all fuel lines for tightness and wear on a regular basis. Tighten or repair them as needed.
- To reduce the hazard of fire, keep the battery compartment, engine, and muffler areas free of grass, leaves, and excessive grease.
- Do not touch the engine, the muffler, or other exhaust components while the engine is running or immediately after stopping the engine. These areas may be hot enough to cause a burn.
- Allow the engine to cool before storing and do not store near an open flame.
- Do not change the engine governor settings or over-speed the engine. Operating engine at excessive speed may increase the hazard of personal injury.
- Springs may contain stored energy. Use caution when disengaging or removing springs and/or spring loaded components.
- An obstruction or blockage in a drive system or moving/rotating parts may cause a buildup of stored energy. When the obstruction or blockage is removed, the drive system or moving/rotating parts may move suddenly. Do not attempt to remove an obstruction or blockage with your hands. Keep hands, feet, and clothing away from all power-driven parts.
- Dispose of all fluids in accordance with local laws.

Fuel Safety



- To avoid personal injury or property damage, use extreme care in handling gasoline. Gasoline is extremely flammable and the vapors are explosive.
- Do not refuel machine while smoking or at a location near flames or sparks.
- Always refuel the machine outdoors.
- Do not store machine or fuel container indoors where fumes or fuel can reach an open flame, spark, or pilot light.
- Only store fuel in an approved container. Keep out of reach of children.
- Never fill containers inside a vehicle or on a truck or trailer bed with a plastic liner. Always place containers on the ground away from your vehicle before filling.
- Remove machine from the truck or trailer and refuel it on the ground. If this is not possible, refuel the machine using a portable container, rather than from a fuel dispenser nozzle.
- Never remove fuel cap or add fuel with the engine running. Allow engine to cool before refueling.
- Never remove fuel cap while on a slope. Only remove when parked on a level surface.
- Replace all fuel tank and container caps securely.

SAFETY



General Safety Procedures for Ventrac Power Units, Attachments, & Accessories



Fuel Safety (continued)

- Do not overfill fuel tank. Only fill to bottom of fuel neck, do not fill fuel neck full. Overfilling of fuel tank could result in engine flooding, fuel leakage from the tank, and/or damage to the emissions control system.
- If fuel is spilled, do not attempt to start the engine. Move the power unit away from the fuel spill and avoid creating any source of ignition until fuel vapors have dissipated.
- If the fuel tank must be drained, it should be drained outdoors into an approved container.
- Dispose of all fluids in accordance with local laws.
- Check all fuel lines for tightness and wear on a regular basis. Tighten or repair them as needed.
- The fuel system is equipped with a shut-off valve. Shut off the fuel when transporting the machine to and from the job, when parking the machine indoors, or when servicing the fuel system.

Hydraulic Safety

- Make sure all hydraulic connections are tight and all hydraulic hoses and tubes are in good condition. Repair any leaks and replace any damaged or deteriorated hoses or tubes before starting the machine.
- Hydraulic leaks can occur under high pressure. Hydraulic leaks require special care and attention.
- Use a piece of cardboard and a magnifying glass to locate suspected hydraulic leaks.



- Keep body and hands away from pinhole leaks or nozzles that eject high pressure hydraulic fluid. Hydraulic fluid escaping under high pressure can penetrate the skin causing serious injury, leading to severe complications and/or secondary infections if left untreated. If hydraulic fluid is injected into the skin, seek immediate medical attention no matter how minor the injury appears.

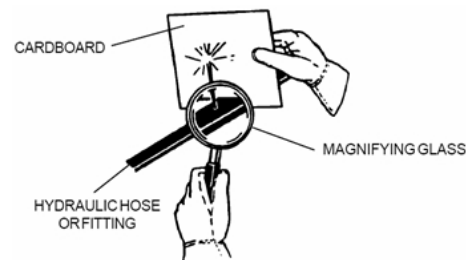

- Hydraulic system may contain stored energy. Before performing maintenance or repairs on the hydraulic system, remove attachments, engage parking brake, disengage weight transfer system (if equipped), shut off engine, and remove ignition key. To relieve pressure on the auxiliary hydraulic system, shut off the power unit engine and move the hydraulic control lever left and right before disconnecting the auxiliary hydraulic quick couplers.
- Dispose of all fluids in accordance with local laws.

SAFETY



KP540 Safety Procedures



- Attachment hydraulic system may contain stored energy. Before performing maintenance or repairs on the hydraulic system, the attachment's auxiliary hydraulic hoses must be disconnected from the power unit. Lower the attachment to the ground, shut off power unit engine, move the secondary S.D.L.A. lever left and right to relieve auxiliary hydraulic pressure, and disconnect the auxiliary hydraulic quick couplers.
- Always wear eye protection when working with the carbide tips.

OPERATIONAL CONTROLS

Height Adjustment Crank

The height adjustment crank (A) controls the depth of the rotor. The crank latch (B) locks the height adjustment crank at the selected height.

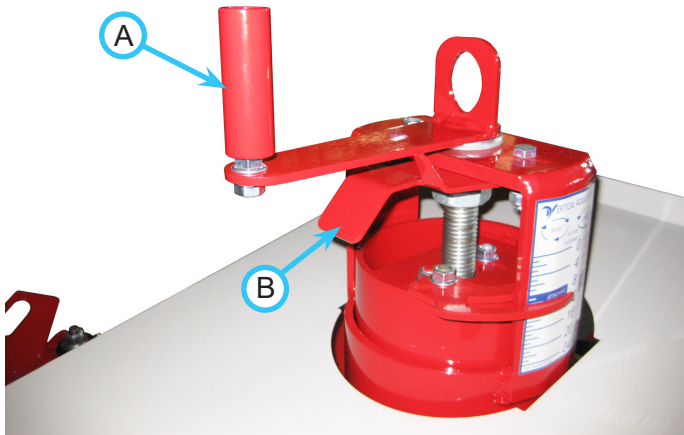

Valve Control Rod (Drum Rotation Valve)

The valve shift handle (C) controls the direction of the rotor drum. Push the control rod forward (away from the operator) when traveling forward. Pull the control rod back toward the operator to reverse the drum when traveling in reverse for back-dragging soil or pulling material away from buildings, trees, or other obstructions.

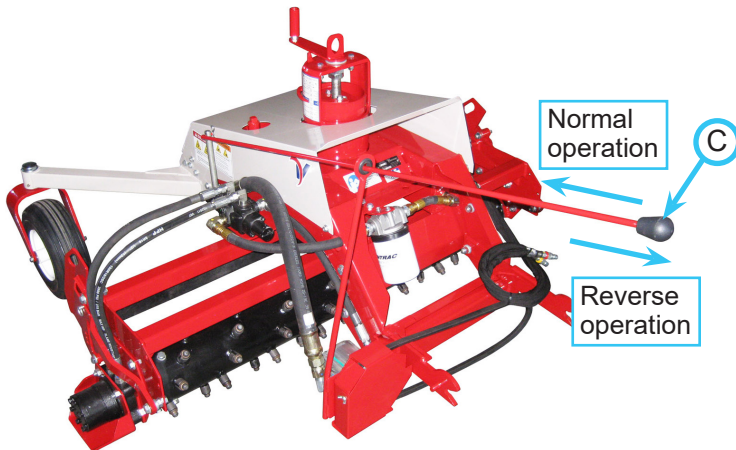

Rotor Angle (Secondary S.D.L.A. Lever*)

The secondary S.D.L.A. lever* on the power unit controls the angle of the power rake's rotor. The power rake rotor can be angled up to 18 degrees to the left or the right.

* Refer to power unit operator's manual for operation of power unit controls.

GENERAL OPERATION

Daily Inspection

WARNING

Always set the parking brake, shut off power unit engine, remove the ignition key, and ensure all moving parts have come to a complete stop before inspecting components, or attempting any repair or adjustment.

1. Park the power unit and power rake on a level surface, with the engine shut off and all fluids cold.
2. Perform a visual inspection of the power unit and power rake. Look for loose or missing hardware, damaged components, damaged or missing carbide tips, or signs of wear. Inspect drive belts. Belts should be in good condition.
3. Inspect hydraulic hoses, hydraulic fittings, and fuel lines to ensure tight, leak free connections. Check the power rake's hydraulic oil level.
4. Refer to the power unit operator's manual. Check the power unit's engine oil, hydraulic oil, cooling system, tire pressure, and fuel level. Add fluid or service system as required.
5. Refer to the power unit operator's manual. Test the power unit's operator safety interlock system.

Attaching

1. Adjust the power rake height until the indicator (A) is located in the attaching zone[^] on the height adjustment decal.



2. Raise the power unit's front hitch to the maximum height and engage the weight transfer system* (if equipped).
3. Drive the power unit slowly forward into the hitch arms of the power rake. Align the lift arms of the power unit with the power rake hitch arms by raising or lowering the front hitch and complete the engagement.

4. Once completely engaged, close the front hitch locking lever.*
5. Engage the parking brake* and shut off the engine.
6. Place the attachment belt onto the PTO drive pulley on the power unit. Ensure the belt is properly seated in each pulley.
7. Engage the PTO spring tension lever* on the power unit.
8. Wipe hose ends clean, and connect to the power unit's hydraulic quick couplers. If equipped, connect the hoses and quick couplers so the red indicators are paired together and the yellow indicators are paired together.

Detaching

1. Adjust the power rake height until the indicator is located in the attaching zone[^] on the height adjustment decal.
2. Park the power unit on a level surface and set the parking brake.*
3. Lower the power rake to the ground.
4. Shut off power unit engine.
5. Disengage the PTO tension spring.
6. Remove the attachment belt from the PTO drive pulley of the power unit.
7. Disconnect the hydraulic quick couplers from the power unit and store the hose ends in the holes in the main frame.

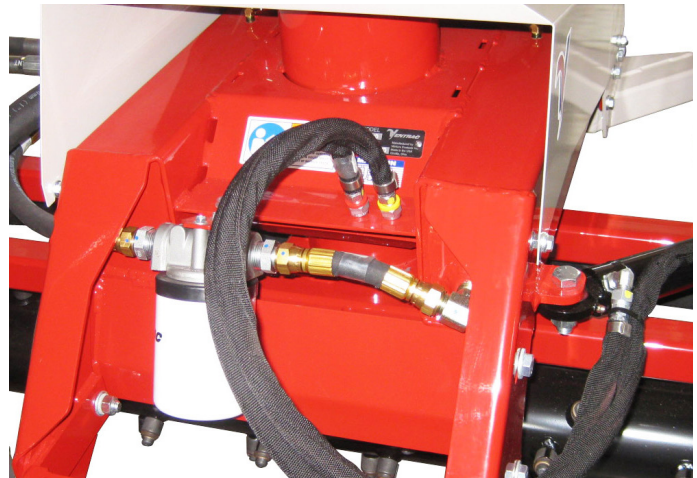

8. Disengage the front hitch locking lever*.
9. Restart the power unit and back slowly away from the power rake.

* Refer to power unit operator's manual for operation of power unit controls.

[^] Attaching zone is set for the standard lift arm height of Ventrac 4000 series power units. Variables such as tire size, tire inflation, and attempting to attach on an uneven surface will affect the proper location of the attaching zone.

GENERAL OPERATION

CAUTION

The power rake is not intended to replace a blade, bulldozer, or loader. The work site should be graded close to its desired state prior to leveling, debris removal, and finishing with power rake.



Attention

Always operate the power rake in the "FLOAT" position. If equipped, set the power unit's weight transfer to maximum.



Attention

Always operate the power rake with the power unit in low range. The deeper the rake drum is set, the slower you will have to travel.

Leveling Work Area Prior to Finish Grading

When smoothing out rough ground, begin by working the soil to a depth of 2-3 inches (5-8 cm).

Depending on soil compaction, it may take several passes while incrementally increasing the rake drum depth to work the soil to the proper depth. It is best if the rake drum is set low enough to carry a pile of dirt ahead of it as you work. This can be any setting of 1 inch (2.5 cm) or more in depth. This will help to fill in low spots while reducing high spots and create a more level surface. Always work the high spots toward the low spots. Changing direction will also help to create a smooth surface (i.e. if working North and South, change direction by 30 or 45 degrees).

TIP: The rake drum can be reversed to pull loose soil and debris away from structures and other obstacles.

TIP: During this initial leveling, the rake will create ridges on one or both sides of the rake. Don't worry about the ridges during this stage. This initial leveling is done to break up the soil, remove high spots, and fill in low spots. The ridges will be smoothed out during finish grading.

Spreading Fill or Topsoil

The rake drum depth will need to be adjusted depending on the amount of material you are moving and the desired depth of the material. Angle the rake drum and lower the side wings as needed to control movement of the material.

Debris Removal

Debris is any unwanted material that is mixed in the soil or gravel you are working. Set the rake drum depth so the carbide teeth are approximately 1/2" (1.25 cm) into the soil. The rake drum should not contact the soil. Angle the rake drum so the debris is raked off to one side. Rake all the debris to the outside edge of the work area and collect. The rake drum can be reversed to pull loose soil and debris away from structures and other obstacles. If there are large amounts of debris in the work area, the side wings can be lowered to help collect the debris while moving it to the edge of the work area. Depending on the soil condition and the amount of debris, several passes over the same spot may be required.

Finish Grading (Lawn Preparation)

Prior to beginning lawn preparation, the soil should be loosened to a depth of 2-3 inches (5-8 cm) as described in the Leveling Work Area section. Set the rake drum depth so the carbide teeth are approximately 1/2-3/4 inch (1.25-2 cm) into the soil. The rake drum should not contact the soil. Begin by angling the rake drum so the soil rolls in the same direction. This will smooth the surface and help to rake debris such as rocks, sticks, tree roots, grass clumps, etc. to the edge of the work area. Depending on the soil condition, several passes over the same spot may be required. The result is a smooth surface that is ready to seed.

Gravel Driveway Restoration

The power rake can also be used to repair driveways, easily removing potholes and loosening compacted gravel, leaving you with a fresh gravel surface without having to add new gravel. For best results, the driveway should be worked when it is damp. The gravel will work easier and create less dust and it will level and pack better.

Begin by working the gravel to a depth of 1-2 inches (2.5-5 cm). If potholes are present in the driveway, the gravel must be worked to a depth of 1/2 to 1 inch (1.25-2.5 cm) lower than the potholes to keep them from returning. If the potholes are just filled shut, they will return in a very short time. When working the gravel on the initial passes, always rake towards the middle of the driveway.

TIP: When working on driveways, lower the side wing on the side closest to the grass to help prevent gravel from overflowing into the grass.

GENERAL OPERATION

Driveway Finish

Lower the power rake to the ground and place the power unit's primary S.D.L.A. control lever in the float position by pushing it to the right until the detent engages. The lever will stay in this position until manually removed. Set the rake drum depth so the carbide teeth are approximately 1/2 inch (1.25 cm) into the gravel. Make one pass down the center of the driveway with the rake straight (perpendicular to the power unit). Angle the rake drum to the left so the motor is close to the left tire on the power unit and make a pass down both sides of the driveway with the edge of the grass on the right. This will provide the smoothest appearance and will put a crown back in the middle of the driveway. Repeat as necessary, until there are no ridges in the driveway.

TIP: You do not want to push dirt while finishing the driveway. If you are pushing dirt, raise the rake drum depth slightly until the teeth are only touching gravel. Travelling too fast will create a bumpy driveway. A good speed is about 75% stroke on the S.D.L.A. lever with the power unit in low range.

Gravel Paths & Walkways

The power rake does an excellent job of maintaining gravel paths and walkways by loosening compacted gravel and removing weeds.

Lower the side wings to help contain the gravel on the walkway. With the rake straight (perpendicular to the power unit), drive slowly along the walkway, while working the gravel to a depth of 1-2 inches (2.5-5 cm). This will level the gravel surface and turn under the weeds, leaving you with a smooth, weed free surface without the use of harsh chemical sprays.

Chemical Free Weeding

The power rake can be used to remove weeds from both gravel and dirt surfaces without the use of weed killing chemicals.

Set the rake drum to a depth of 1-2 inches (2.5-5 cm) and work the gravel or soil to remove the weeds. Loose weeds can then be raked to the edge of the work area (debris removal) and collected.

Operating Procedure

Before operation, perform daily inspection, set the power unit's weight transfer to maximum (if equipped), and set the rake drum to the desired depth. Place the side wings in the appropriate position for the conditions and type of work.

Move the machine into position and lower the power rake to the ground. Place the power unit's primary

SDLA control lever in the float position by pushing it to the right until the detent engages. The lever will stay in this position until manually removed.

Moving the secondary SDLA lever left or right will cause the rake drum to angle to allow for windrowing of debris to either side. Make sure to raise the side containment flaps if the rake is angled, to allow the debris to flow off the end of the rake drum.

WARNING

When the rake drum is angled to the left or right, pinch points are created. Make sure there are no people or objects present between the rake drum, rake frame, and power unit.

With the power unit's engine running between 2,000 and 2,500 RPM, engage the PTO switch to start the drum rotation and set the drum to rotate in the proper direction.

The valve control rod that controls the direction of the drum rotation can be reached by the operator from the power unit seat. Push the control rod forward (away from the operator) when traveling forward and pull the control rod back toward the operator when traveling in reverse.

Adjust the power unit throttle and drive forward slowly. Run the power rake at full throttle for most applications. In extremely hard packed conditions or if there is a lot of large debris present in the soil, it may be beneficial to reduce the engine RPM so the rake drum turns slower.

If debris becomes wrapped around the rake drum, it will reduce the performance of the power rake. Clean the rake drum as needed.

While the power rake will work in either travel direction, it is recommended that the majority of the work be done in the forward direction for operator comfort. If the power unit tire tracks are undesirable in the finished surface, the final pass can be done in the reverse direction to remove them.

GENERAL OPERATION

Cleaning Debris From Rake Drum

If debris such as wire, rope, vines, etc. becomes wrapped around the rake drum during use, stop the power unit and raise the power rake off the ground. Reverse the rake drum rotation to allow the debris to unwind from the drum. The drum rotation may need to be changed back and forth several times until all the debris is removed.

A yellow rectangular warning box with a black border. Inside the box, on the left, is a black triangle with a white exclamation mark. To the right of the triangle, the word "CAUTION" is written in bold, black, uppercase letters.

If debris becomes wrapped around the bearing or motor shaft at the ends of the rake drum, cease operation immediately and remove the debris. Continued operation could damage the machine.

Transport of Power Rake

Transport the power rake with the power unit front hitch and power rake raised to reduce wear of the machine and to prevent the rake from catching on high spots in the ground, rocks, or other obstacles. Travel slowly when transporting over undulating or rough surfaces to maintain control of the power unit and reduce the shock to the machine.

Setting Rake Drum Depth

Hold the crank latch down, while turning the height adjustment crank. Turn the height adjustment crank clockwise to raise the rake drum and counterclockwise to lower the rake drum. Release the crank latch to lock the height adjustment crank at the selected position.

Dirt Flap

The Power Rake has a containment flap that can be adjusted to the rake drum. Adjusting the flap closer to the rake drum will keep smaller sized debris from passing through the drum, and give the most debris free soil. However depending on conditions it can also cause unwanted soil removal. Setting the flap farther away from the rake drum will allow more debris to pass through the power rake and not be removed from the soil.

A flap setting of approximately 3/4-1 inch (2-2.5 cm) from the carbide teeth works well for most applications.

SERVICE

⚠ WARNING

Always set the parking brake, shut off power unit engine, remove the ignition key, and ensure all moving parts have come to a complete stop before inspecting components or attempting any repair or adjustment.



Attention

If any component requires replacement, use only original Ventrac replacement parts.

Cleaning and General Maintenance

For best results, and to maintain the finish of the KP540, clean or wash the power rake to remove dirt, gravel, and debris. Remove any debris that may be stuck in or wrapped around the rotor.

Drive Belt Inspection

Inspecting the drive belts of the snow blower can prevent sudden belt failure by finding problems before they cause a belt to break.

Typical wear on a drive belt may result in the conditions shown in the diagram. If any of these conditions occur, the drive belt will require replacement.

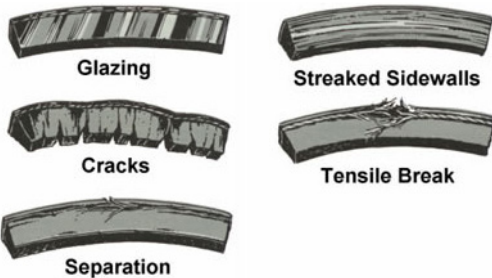

Drive Belt Replacement

1. Remove the power rake from the power unit.
2. Remove the wing nut and drive pulley shield from the power rake.
3. Remove the old drive belt and install the new drive belt onto the drive pulley.
4. Reinstall the drive pulley shield and wing nut.

Tire Pressure

Tire pressure should be maintained at 18-20 PSI. Pressure variance between the left and right tires can cause uneven results.

Carbide Tip Replacement

If the carbide tips become excessively worn or damaged, they will need to be replaced.

⚠ WARNING

Always use eye protection when working with carbide tips.

1. Remove the carbide tip using a cold chisel and a hammer. Place the chisel in the slot in the protective sleeve with the tip against the bottom flange of the carbide tip and hammer the carbide tip out of the sleeve.
2. Use a channel lock pliers to compress the retainer ring on the carbide tip.
3. Insert the carbide tip into the rotor sleeve and tap in with a hammer.



Checking Hydraulic Oil Level

Check hydraulic oil level before operating unit when the hydraulic system is cold. If the hydraulic system is warm, allow 1 hour for the hydraulic system to cool before checking. If the hydraulic system is warm when the oil level is checked, it will produce an inaccurate oil level reading.

1. Park the power rake on a level surface and allow time for the hydraulic system to cool, if necessary.
2. Remove the dipstick (A) from the hydraulic oil tank and wipe with a clean cloth.

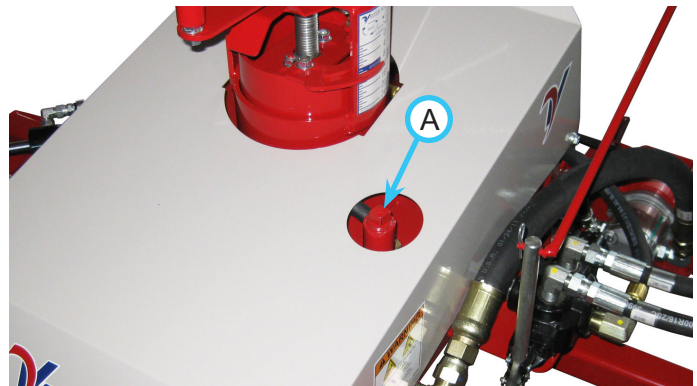

3. Set the dipstick back in place without threading in.
4. Check the oil level. The level should be between the two notches on the dipstick.

SERVICE

5. If hydraulic oil level is low, add HydroTorq XL synthetic hydraulic oil until the proper level is reached.
6. Reinstall the dipstick into the hydraulic oil tank.

Changing Hydraulic Oil & Filter

1. Angle the rotor assembly so the left side is angled back toward the power unit.
1. Park the power rake on a level surface and detach from the power unit.
2. Lower the rotor on the power rake until the rear of the hydraulic oil tank is slightly higher than the front of the tank.
3. Place a drain pan of sufficient size under the tee fitting in the front of the tank.
4. Remove the cap (A) from the end of the tee fitting to drain the oil. Using a hoist to lift up the right side of the power rake will also assist in draining the oil.

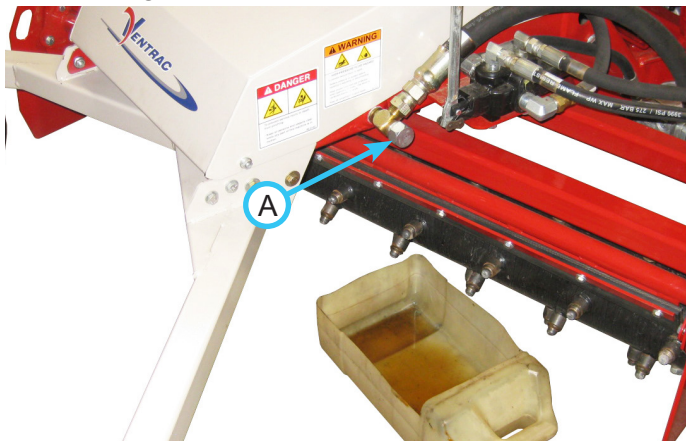

5. After draining the oil, lower the power rake to the ground and reinstall the cap onto the tee fitting.
6. Remove the filter (B) from the power rake.
7. Wipe the filter mounting surface with a clean cloth.
8. Apply a thin film of clean oil to the gasket on the new filter.
9. Install the new filter.
NOTE: Turn the filter clockwise until the filter gasket makes contact with the mounting surface. Tighten 1/2 - 3/4 turn after gasket contact.
10. Remove the dipstick from the hydraulic oil tank and add HydroTorq XL synthetic hydraulic oil until the proper level is reached.
11. Reinstall the dipstick into the hydraulic oil tank.

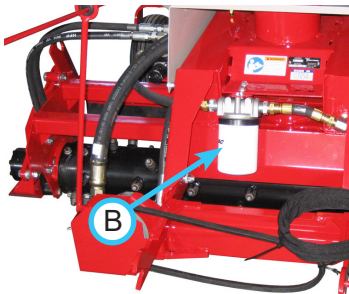

Power Rake Frame Leveling

Variables such as tire size, tire inflation, power unit hitch height, or hitch arm replacement may require one to level the main frame of the power rake.

1. Park the power unit and power rake on a level surface and set the parking brake.
2. Adjust the rotor height until the rotor clears the surface by approximately 1/2 inch (13 mm).
3. Place the power unit's primary S.D.L.A. lever in the float position.
4. Angle the rotor assembly so the left side is angled forward away from the power unit.
5. Measure from a location on the rotor frame down to the level surface.



6. Angle the rotor assembly so the left side of the rotor is angled back toward the power unit.
7. Measure from the same side and location on the rotor frame down to the level surface. If this measurement is more than 1/8" (3 mm) to 1/4" (6 mm) different than the first measurement, the main frame should be leveled.*
8. Adjust the rotor height until the rotor is setting on the level surface.
9. Loosen the 6 bolts (C) (3 on each side) that secure the hitch frame to the main frame.

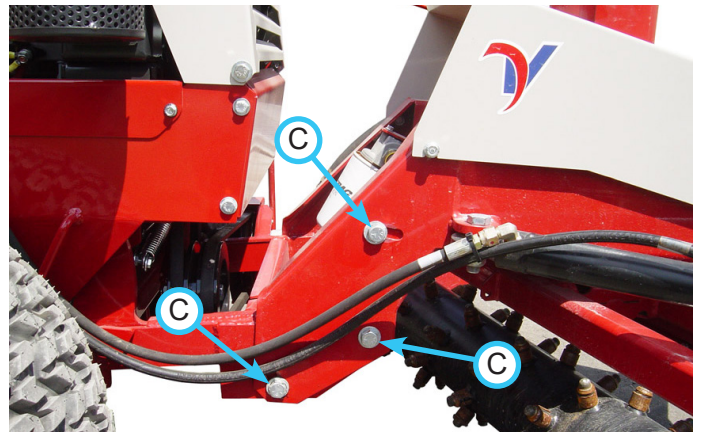

SERVICE

10. Start the power unit engine and raise or lower the power unit's front hitch to change the angle between the hitch frame and the main frame.
11. Tighten the 6) bolts that secure the hitch frame to the main frame. Torque to 75 ft-lbs (102 Nm).
12. Repeat steps 2-11 until the rotor frame measurements are within 1/8" (3 mm) to 1/4" (6 mm).*

*1/8" (3 mm) to 1/4" (6 mm) is generally preferred for most applications. Some applications may require a finer adjustment.

NOTE: The above procedure may also be used to adjust the power rake to an intentional rotor angle.

Lubrication Locations

Lubrication is required at the following locations, using a lithium complex NGLI #2 grease. Refer to the maintenance schedule for service intervals.

When applying grease to the threads on the height adjust crank, lower the rotor and frame completely to expose as much of the threads as possible. Apply grease until threads are coated.

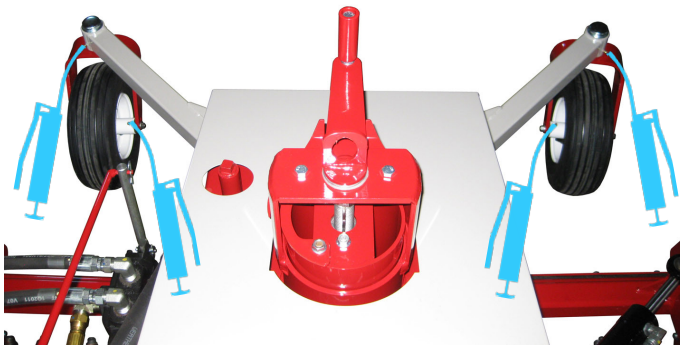

Storage

Preparing the Power Rake for Storage

1. Clean the power rake.
2. Inspect for loose or missing hardware, damaged components, or signs of wear.
3. Inspect safety decals. Replace any safety decals that are faded, illegible, or missing.
4. Inspect hydraulic hoses and fittings to ensure tight, leak free connections. Repair or replace any damaged or worn components.
5. Inspect drive belt for signs of damage or wear and replace as required.
6. Service all lubrication points and inspect hydraulic oil level.
7. Wipe off all excess grease or oil.

Removing the Power Rake from Storage

1. Clean the power rake to remove any accumulated dust or debris.
2. Inspect the power rake as instructed in the daily inspection section of this manual.
3. Test the power rake to ensure all components are working properly.

SERVICE

Maintenance Schedule

Maintenance Schedule		Maintenance Intervals																											
		# of Locations	# of Pumps	AS NEEDED	Daily	At 50 Hours	At 100 Hours	At 150 Hours	At 200 Hours	At 250 Hours	At 300 Hours	At 350 Hours	At 400 Hours	At 450 Hours	At 500 Hours	At 550 Hours	At 600 Hours	At 650 Hours	At 700 Hours	At 750 Hours	At 800 Hours	At 850 Hours	At 900 Hours	At 950 Hours	At 1000 Hours	5 Years or 500 Hrs.	5 Years or 2000 Hrs.		
Grease & Lubrication: See Lubrication Section																													
Cylinder End Pivots	2	^	**		✓	✓	✓	✓	✓	✓	✓	✓	✓	✓	✓	✓	✓	✓	✓	✓	✓	✓	✓	✓	✓	✓	✓	✓	
Caster Wheel Pivot	2	1			✓	✓	✓	✓	✓	✓	✓	✓	✓	✓	✓	✓	✓	✓	✓	✓	✓	✓	✓	✓	✓	✓	✓	✓	
Wheel Axle Bearing	2	^	**		✓	✓	✓	✓	✓	✓	✓	✓	✓	✓	✓	✓	✓	✓	✓	✓	✓	✓	✓	✓	✓	✓	✓	✓	
Rotor Bearing	1	1	**		✓	✓	✓	✓	✓	✓	✓	✓	✓	✓	✓	✓	✓	✓	✓	✓	✓	✓	✓	✓	✓	✓	✓	✓	
Height Adjust Crank	1	&			✓	✓	✓	✓	✓	✓	✓	✓	✓	✓	✓	✓	✓	✓	✓	✓	✓	✓	✓	✓	✓	✓	✓	✓	
Hydraulic System																													
Check Hydraulic Oil Level				✓																									
Change Hydraulic Filter																											✓		
Change Hydraulic Oil																												✓	
Inspection																													
Inspect for Loose, Missing, or Worn Components.				✓																									
Inspect Drive Belt, Hydraulic Hoses, & Fittings				✓																									
Inspect Carbide Tips				✓																									
Check Tire Pressure				✓																									
Inspect Safety Decals				✓																									
** Operation in severe conditions may require more frequent service intervals.																													
^ Grease until fresh grease is visible.																													
& Apply grease until threads are coated.																													

Maintenance Checklist

Maintenance Checklist		Maintenance Intervals																											
		# of Locations	# of Pumps	At 50 Hours	At 100 Hours	At 150 Hours	At 200 Hours	At 250 Hours	At 300 Hours	At 350 Hours	At 400 Hours	At 450 Hours	At 500 Hours	At 550 Hours	At 600 Hours	At 650 Hours	At 700 Hours	At 750 Hours	At 800 Hours	At 850 Hours	At 900 Hours	At 950 Hours	At 1000 Hours	5 Years or 500 Hrs.	5 Years or 2000 Hrs.				
Grease & Lubrication: See Lubrication Section																													
Cylinder End Pivots	2	^																											
Caster Wheel Pivot	2	1																											
Wheel Axle Bearing	2	^																											
Rotor Bearing	1	1																											
Height Adjust Crank	1	&																											
Hydraulic System																													
Check Hydraulic Oil Level																													
Change Hydraulic Filter																													
Change Hydraulic Oil																													
Inspection																													
Inspect for Loose, Missing, or Worn Components.																													
Inspect Drive Belt, Hydraulic Hoses, & Fittings																													
Inspect Carbide Tips																													
Check Tire Pressure																													
Inspect Safety Decals																													
** Operation in severe conditions may require more frequent service intervals.																													
^ Grease until fresh grease is visible.																													
& Apply grease until threads are coated.																													

SPECIFICATIONS

Dimensions

Overall Height	36 inches (91.5 cm)
Overall Length	59 inches (150 cm)
Overall Length w/Valve Shift Handle	70.5 inches (179 cm) to 75 inches (190.5 cm)
Overall Width	63 inches (160 cm)
Rotor Width	54 inches (137 cm)
Weight	536 pounds (243 kg)
Hydraulic Fluid Capacity	4.5 gallons (17 L)
Height Adjustment Range	3.5 inches (9 cm)
Power Angle	18 degrees

Features

- 72 carbide tips can be replaced without removing the rotor.
- Single rotating height adjustment handle for fast and accurate adjustments.
- Hydraulic driven rotor with reversible rotation controlled from operator seat.
- Hydraulic power angle control.
- Adjustable end plates for material control.

SPECIFICATIONS

Noise Emissions¹

Measured Sound Power Level, dB(A)	96.6
Sound Power Uncertainty, dB(A)	2.0
Sound Pressure Level at Operator's Ear, dB(A)	86.0
Sound Pressure Uncertainty, dB(A)	2.0

Note 1: Specifications subject to change without notice.

EC Declaration of Conformity

Ventrac KP540

Manufacturer	Venture Products, Inc. 500 Venture Drive Orrville, OH 44667 USA
Authorized Representative (also authorized to compile the technical file)	Lars Persson LAPAB MASKIN AB Box 46, S-734 22 Hallstahammar Flädervägen 5, 734 38 Hallstahammar SWEDEN
Technical File Keeper	Ryan Steiner Venture Products, Inc. 500 Venture Drive Orrville, OH 44667 USA
Description	Power rake attachment
Model Name	Ventrac KP540 Power Rake
Model Number	39.55435
Serial Number	KP540-Axxxxx
This Product Conforms to Directives	2006/42/EC
Ryan Steiner Director of Engineering 	23-July-2015 Orrville, Ohio USA

PARTS

ILLUSTRATED DRAWING Hydraulic Diagram & O-Ring Chart

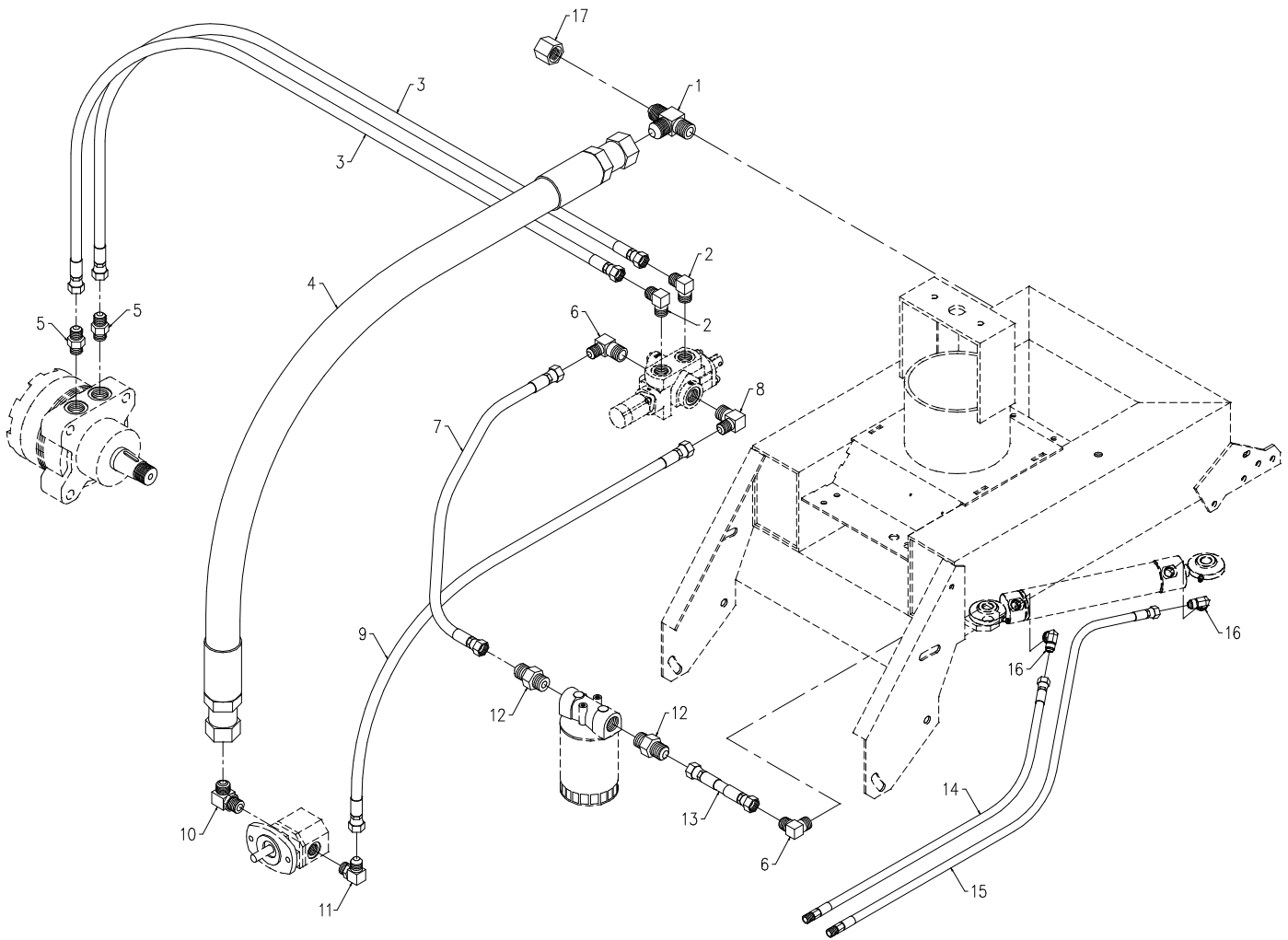

PARTS

Hydraulic Diagram & O-Ring Chart

REF.	PART NO.	DESCRIPTION	QTY.
1	25.2605-12-12-12	.FITTING, M TEE 3/4 X 3/4 X 3/4	1
2	25.2501-08-08	.FITTING, 90 ME 1/2 X 1/2	2
3	20.0182	.HOSE, 1/2X27.50 SAE 100R17 AR	2
4	22.0032	.HOSE, 1X30.00 SAE 100R3	1
5	25.6400-08-10	.FITTING, M CONN 1/2 X 5/8	2
6	25.2501-10-12	.FITTING, 90 ME 5/8 X 3/4	2
7	22.0031	.HOSE, 5/8X16.00 PLK 250PSI CPE	1
8	25.2501-08-12	.FITTING, 90 ME 1/2 3/4	1
9	20.0186	.HOSE, 1/2X19.00 SAE 100R17 AR	1
10	25.6801-12-12	.FITTING, 90 ME 3/4 X 3/4	1
11	25.6801-08-10	.FITTING, 90 ME 1/2 X 5/8	1
12	25.2404-10-12	.FITTING, M CONN 5/8 X 3/4	2
13	22.0030	.HOSE, 5/8X6.00 PLK 250PSI CPE	1
14	20.0169	.HOSE, 1/4X38.00 SAE 100R17 AR	1
15	20.0185	.HOSE, 1/4X48.00 SAE 100R17 AR	1
16	25.6801-06-06	.FITTING, 90 ME 3/8 X 3/8	2
17	25.304-C-12	.FITTING, CAP 3/4 #12 JIC	1

Straight Thread O-Ring Boss - O-Ring Replacement Part Numbers

SAE Fitting Size	Thread Size	VPI Part #	ID	OD	Width	AS568A Dash #
-04	7/16-20	26.0035	0.351"	0.495"	0.072"	904
-06	9/16-18	26.0036	0.468"	0.624"	0.078"	906
-08	3/4-16	26.0037	0.644"	0.818"	0.087"	908
-10	7/8-14	26.0038	0.755"	0.949"	0.097"	910
-12	1-1/16-12	26.0039	0.924"	1.156"	0.116"	912
-16	1-5/16-12	26.0043	1.171"	1.403"	0.116"	916

O-Ring Face Seal Hose - O-Ring Replacement Part Numbers

SAE Fitting Size	Thread Size	VPI Part #	ID	OD	Width	AS568A Dash #
-04	9/16-18	26.0044	0.301"	0.441"	0.070"	011
-06	11/16-16	26.0025	0.364"	0.504"	0.070"	012
-08	13/16-16	26.0009	0.489"	0.629"	0.070"	014
-10	1-14	26.0023	0.614"	0.754"	0.070"	016
-12	1-3/16-12	26.0045	0.739"	0.879"	0.070"	018
-16	1-7/16-12	26.0046	0.926"	1.066"	0.070"	021

PARTS

ILLUSTRATED DRAWING Main Frame, Hitch Frame, & Filter

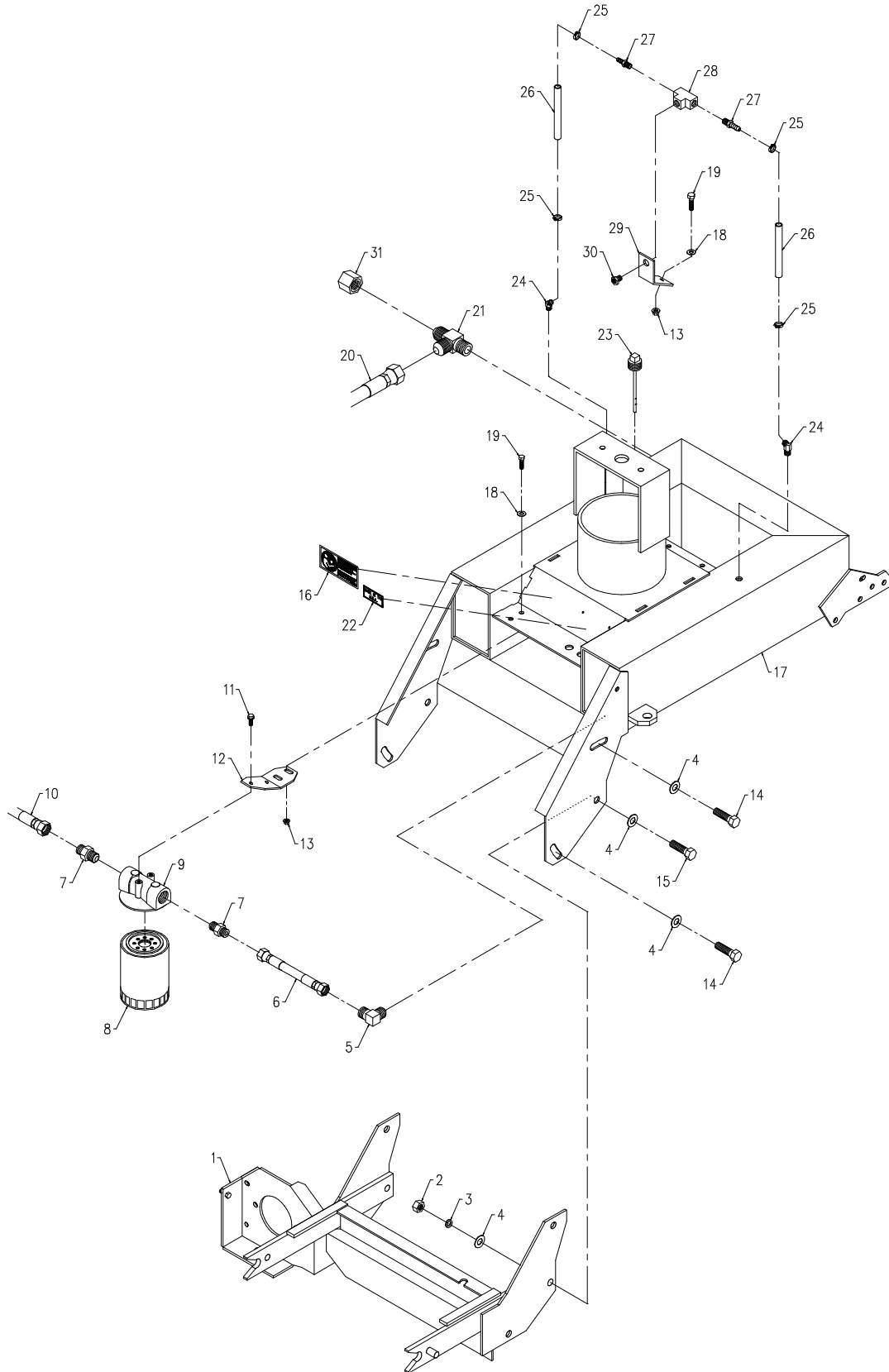

PARTS

Main Frame, Hitch Frame, & Filter

REF.	PART NO.	DESCRIPTION	QTY.
1	62.0939	.FRAME, HITCH.	1
2	92.08	.NUT, 1/2-13 USS	6
3	96.08	.WASHER, LOCK 1/2	6
4	95.08	.WASHER, FLAT 1/2 SAE	6
5	25.2501-10-12	.FITTING, 90 ME 5/8 X 3/4	1
6	22.0030	.HOSE, 5/8X6.00 PLK 250PSI CPE	1
7	25.2404-10-12	.FITTING, M CONN 5/8 X 3/4	2
8	21.0078	.FILTER, HYDRAULIC 10 MICRON	1
9	21.0057	.FILTER, HEAD 3/4" NPT PORTS	1
10	22.0031	.HOSE, 5/8X16.00 PLK 250PSI CPE	1
11	99.SF0404-1	.BOLT, SMF 1/4-20 X 1/2	2
12	64.1009	.BRACKET, OIL FILTER MOUNT	1
13	99.SF05	.NUT, SRF 5/16-18 USS	3
14	90.0810	.BOLT, 1/2-13 USS X 1 1/4	4
15	90.0814	.BOLT, 1/2-13 USS X 1 3/4	2
16	00.0217	.DECAL, WARNING READ OWNERS MAN	1
17	62.0937	.FRAME, MAIN BODY	1
18	95.05	.WASHER, FLAT 5/16 SAE	3
19	90.0506	.BOLT, 5/16-18 USS X 3/4	3
20	22.0032	.HOSE, 1X30.00 SAE 100R3	1
21	25.2605-12-12-12	.FITTING, M TEE 3/4 X 3/4 X 3/4	1
22	00.0100	.DECAL, MADE IN USA	1
23	23.0134	.DIP STICK, OIL TANK	1
24	29.BF06MP0245	.FITTING, 3/8 BARB X 1/8 MP 45	2
25	11.0032	.CLAMP, HOSE S/S 7/16-25/32	4
26	27.P06-6IN	.HOSE, PUSHLOCK X 3/8 X 6"	2
27	29.BF06MP04	.FITTING, 3/8 BARB X 1/4 MP ST	2
28	25.3700-4-4-4	.FITTING, F TEE 1/4 X 1/4 X 1/4	1
29	64.1076	.BRACKET, BREATHER TUBE MOUNT	1
30	29.0093	.PIPE, BREATHER PLUG 1/4	1
31	25.304-C-12	.FITTING, CAP 3/4 #12 JIC	1

PARTS

ILLUSTRATED DRAWING Hydraulic Pump, Valve, & Shift Handle

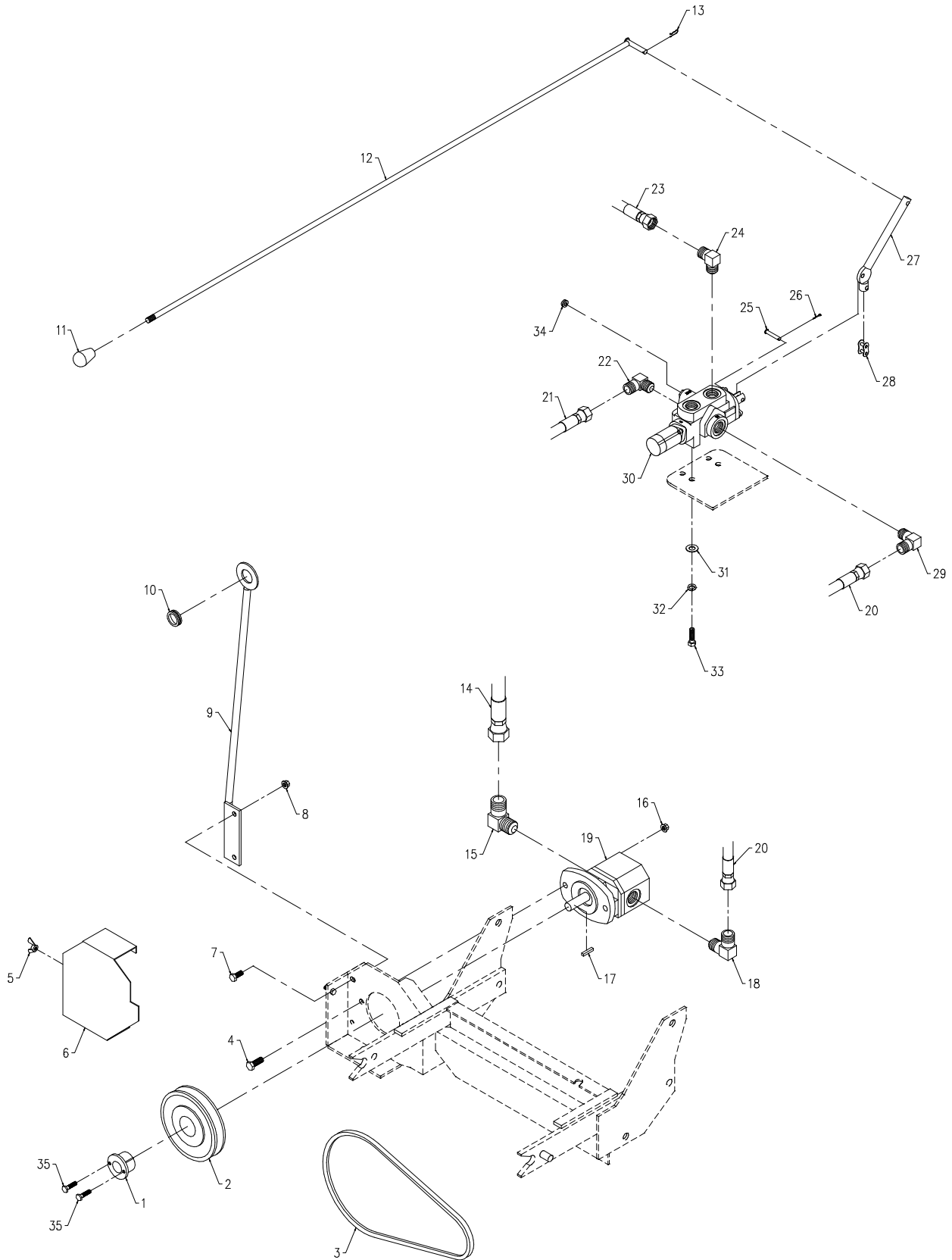

PARTS

Hydraulic Pump, Valve, & Shift Handle

REF.	PART NO.	DESCRIPTION	QTY.
1	83.H12	.BUSHING, 3/4" H (Serial # 1178-1439)	1
1	83.H10	.BUSHING, 5/8" H (Serial # 1440-1487)	1
1	83.H12	.BUSHING, 3/4" H (Serial # 1488-)	1
2	83.BK60H	.PULLEY, 6" H-BUSH.	1
3	81.B048	.BELT, B48	1
4	90.0608	.BOLT, 3/8-16 USS X 1	2
5	99.E0004	.NUT, WING 1/4-20 USS	1
6	60.0721	.SHIELD, DRIVE PULLEY	1
7	90.0506	.BOLT, 5/16-18 USS X 3/4	2
8	99.SF05	.NUT, SRF 5/16-18 USS	2
9	64.1012	.MOUNT, SHIFT ROD SUPPORT	1
10	05.0045	.GROMMET, 3/4ID,1 3/8OD,1/2THK	1
11	47.0001	.KNOB, SM. #80 3/8-16 THREAD	1
12	42.0452	.ROD, VALVE CONTROL	1
13	02.HP0313	.HAIRPIN, 3/32 X 1-5/8	1
14	22.0032	.HOSE, 1X30.00 SAE 100R3	1
15	25.6801-12-12	.FITTING, 90 ME 3/4 X 3/4	1
16	99.SF06	.NUT, SRF 3/8-16 USS	2
17	85.K0310	.KEY, 3/16 X 1 1/4 (Serial # 1178-1439)	1
17	85.K0307	.KEY, 3/16 X 5/8 (Serial # 1440-)	1
18	25.6801-08-10	.FITTING, 90 ME 1/2 X 5/8	1
19	21.0103	.PUMP, BARNES CW 16 CCR (Serial # 1178-1439)	1
19	21.0127	.PUMP, HYD PARKER CW 16CC (Serial # 1440-1487)	1
19	21.0133	.PUMP, HYD PARKER CW 16CC (Serial # 1488-)	1
20	20.0186	.HOSE, 1/2X19.00 SAE 100R17 AR	1
21	22.0031	.HOSE, 5/8X16.00 PLK 250PSI CPE	1
22	25.2501-10-12	.FITTING, 90 ME 5/8 X 3/4	1
23	20.0182	.HOSE, 1/2X27.50 SAE 100R17 AR	2
24	25.2501-08-08	.FITTING, 90 ME 1/2 X 1/2	2
25	03.0408	.CLEVIS PIN, 1/4 X 1"	1
26	02.CP0304	.COTTER PIN, 3/32 X 1/2	1
27	23.0121-4	.HANDLE, VALVE DRILLED	1
28	81.0024	.LINK, CONNECTOR #60	1
29	25.2501-08-12	.FITTING, 90 ME 1/2 3/4	1
30	23.0121-1	.VALVE, 23.0121 W/OUT HANDLE	1
	23.0121-2	.BRACKET, CONTROL LEVER ENERGY	1
	89.0091	.KIT, SEAL FOR 23.0121-1	1
31	95.06	.WASHER, FLAT 3/8 SAE	4
32	96.06	.WASHER, LOCK 3/8	4
33	90.0606	.BOLT, 3/8-16 USS X 3/4	4
34	85.SS22	.SET SCREW, 1/2-20 X 1/4"	1
35	90.0408	.BOLT, 1/4-20 USS X 1	2

PARTS

ILLUSTRATED DRAWING Rotor Frame, Rotor, & Motor

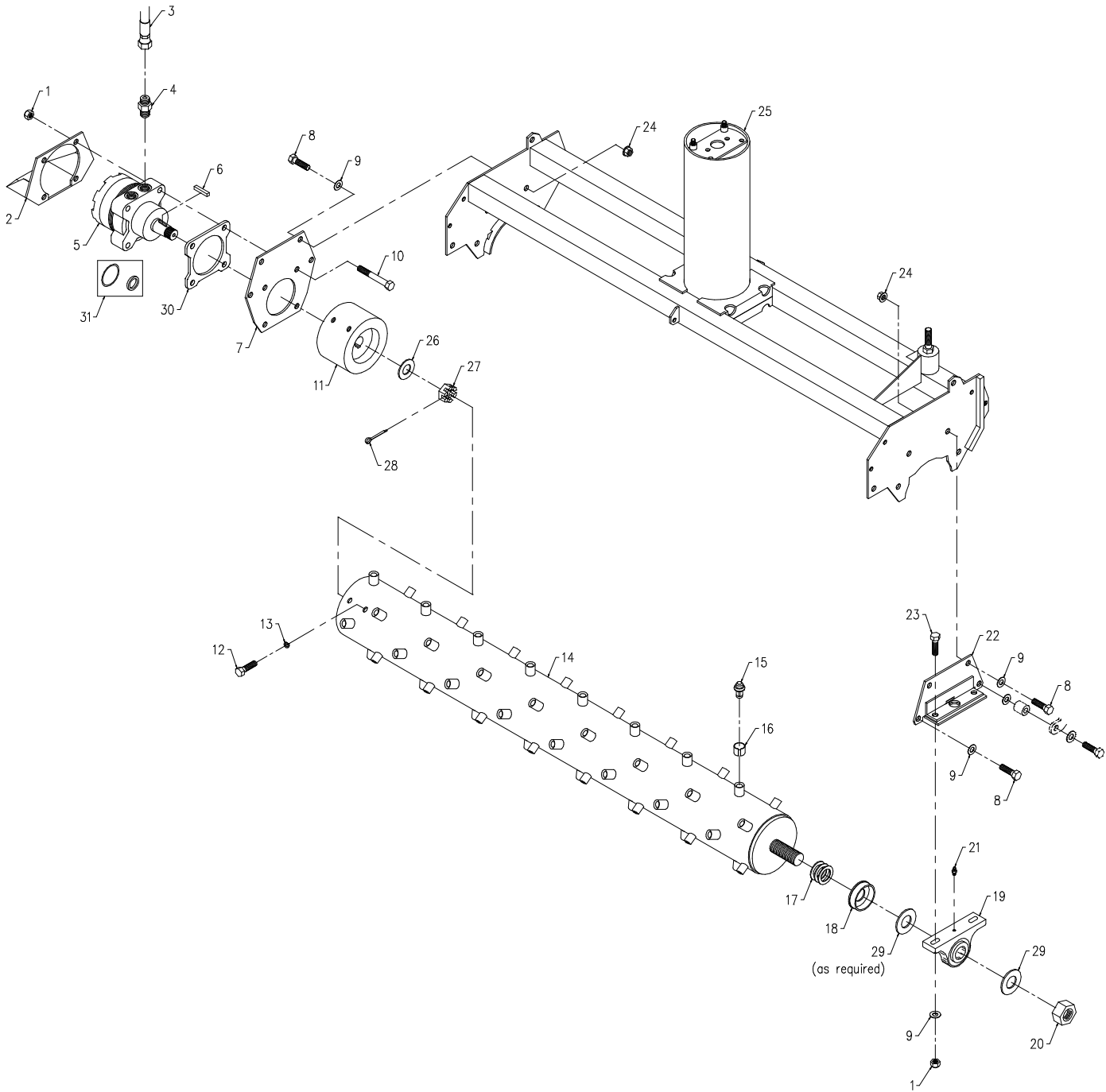

PARTS

Rotor Frame, Rotor, & Motor

REF.	PART NO.	DESCRIPTION	QTY.
1	99.A08	.LOCKNUT, STOVER 1/2-13 USS	4
2	60.0841	.GUARD, ROTOR MOTOR	1
3	20.0182	.HOSE, 1/2X27.50 SAE 100R17 AR	2
4	25.6400-08-10	.FITTING, M CONN 1/2 X 5/8	2
5	21.0120	.MOTOR, WHEEL PEERLESS 250CC (Serial # 1178-1247)	1
5	21.0125	.MOTOR, HYD. PARKER 238CC (Serial # 1248-)	1
6	85.K0510	.KEY, 5/16 X 1 1/4 (Serial # 1178-1247)	1
6	85.W0508	.KEY, WOODRUFF 5/16 X 1 (Serial # 1248-)	1
7	62.0942	.MOUNT, HYD ROTOR MOTOR	1
8	90.0808	.BOLT, 1/2-13 USS X 1	6
9	95.08	.WASHER, FLAT 1/2 SAE	8
10	90.0822	.BOLT, 1/2-13 USS X 2 3/4	4
11	50.0176	.HUB, DRIVE KP540 1"SHAFT	1
12	91.0808	.BOLT, 1/2-20 SAE X 1	6
13	96.08	.WASHER, LOCK 1/2	6
14	80.0324	.ROTOR, DRUM	1
15	79.0052	.TOOTH, CARBIDE 8620 CASE HARD	72
16	79.0052-1	.SLEEVE, PROTECTIVE 7/8X1X3/4 (Serial # 1178-1475)	72
16	64.1999	.SLEEVE, PROTECTIVE (Serial # 1476-)	72
17	95.20	.WASHER, FLAT 1 1/4 SAE	3
18	64.1014	.SHIELD, BEARING DIRT COVER	1
19	55.PB25020-1	.BEARING, PB 1-1/4 DRILL/TAPPED	1
20	93.20	.NUT, 1 1/4-12 SAE	1
21	29.GF0001	.GREASE FTG, 1/4 SAE ST	1
22	64.1005	.MOUNT, ROTOR BEARING	1
23	90.0814	.BOLT, 1/2-13 USS X 1 3/4	2
24	99.SF08	.NUT, SRF 1/2-13 USS	6
25	62.0938	.FRAME, ROTOR MOUNT	1
26	95.16	.WASHER, FLAT 1 SAE	1
27	99.E0069	.NUT, CASTLE 1"-20 UNEF	1
28	02.CP0516	.COTTER PIN, 5/32 X 2	1
29	99.B0078	.WASHER, MACH 1 1/4 14 GA	3
30	64.1243	.PLATE, SPACER HYD ROTOR MOTOR	1
31	89.0087	.KIT, SEAL FOR 21.0120 MOTOR (Serial # 1178-1247)	1
31	89.0090	.KIT, SEAL FOR 21.0125 MOTOR (Serial # 1248-)	1

PARTS

ILLUSTRATED DRAWING Height Adjuster

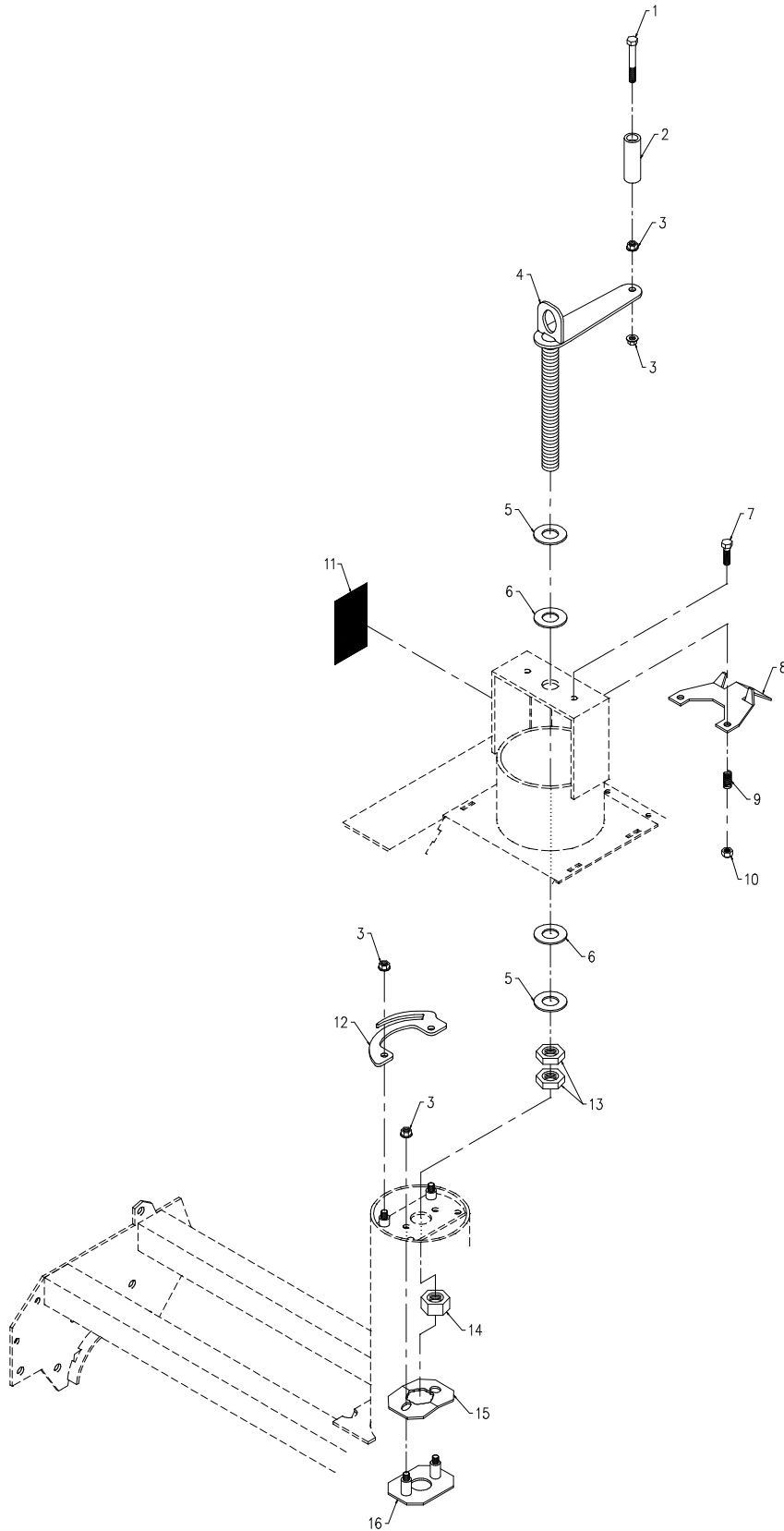

PARTS

Height Adjuster

REF.	PART NO.	DESCRIPTION	QTY.
1	90.0628	.BOLT, 3/8-16 USS X 3 1/2.	1
2	47.0465	.KNOB, HEIGHT ADJUSTER HANDLE	1
3	99.SF06	.NUT, SRF 3/8-16 USS.	6
4	42.0451	.CRANK, HEIGHT ADJUST.	1
5	95.16	.WASHER, FLAT 1 SAE.	2
6	05.0096	.WASHER, UHMW 2-1/16X1-1/32X1/8	2
7	90.0612	.BOLT, 3/8-16 USS X 1 1/2.	2
8	64.1008	.LATCH, HEIGHT CRANK	1
9	41.0039	.SPRING, COMP. 9/16 OD X 5/8.	2
10	99.A06	.LOCKNUT, STOVER 3/8-16 USS	2
11	00.0230	.DECAL, KP HEIGHT ADJUSTMENT.	1
12	64.1242	.PLATE, DEPTH POINTER/RETAINER	1
13	99.E0066	.NUT, JAM 1 USS.	2
14	92.16	.NUT, 1 USS	1
15	64.1011	.CLAMP, HEIGHT NUT LOCK.	1
16	64.1007	.BRACKET, HEIGHT NUT RETAINER	1

PARTS

ILLUSTRATED DRAWING Wheel Frame & Shields

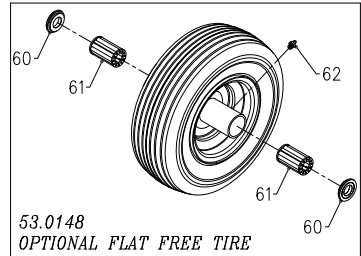
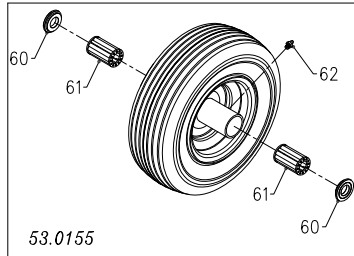
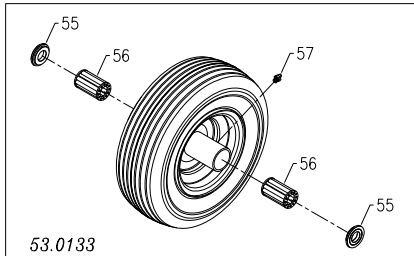
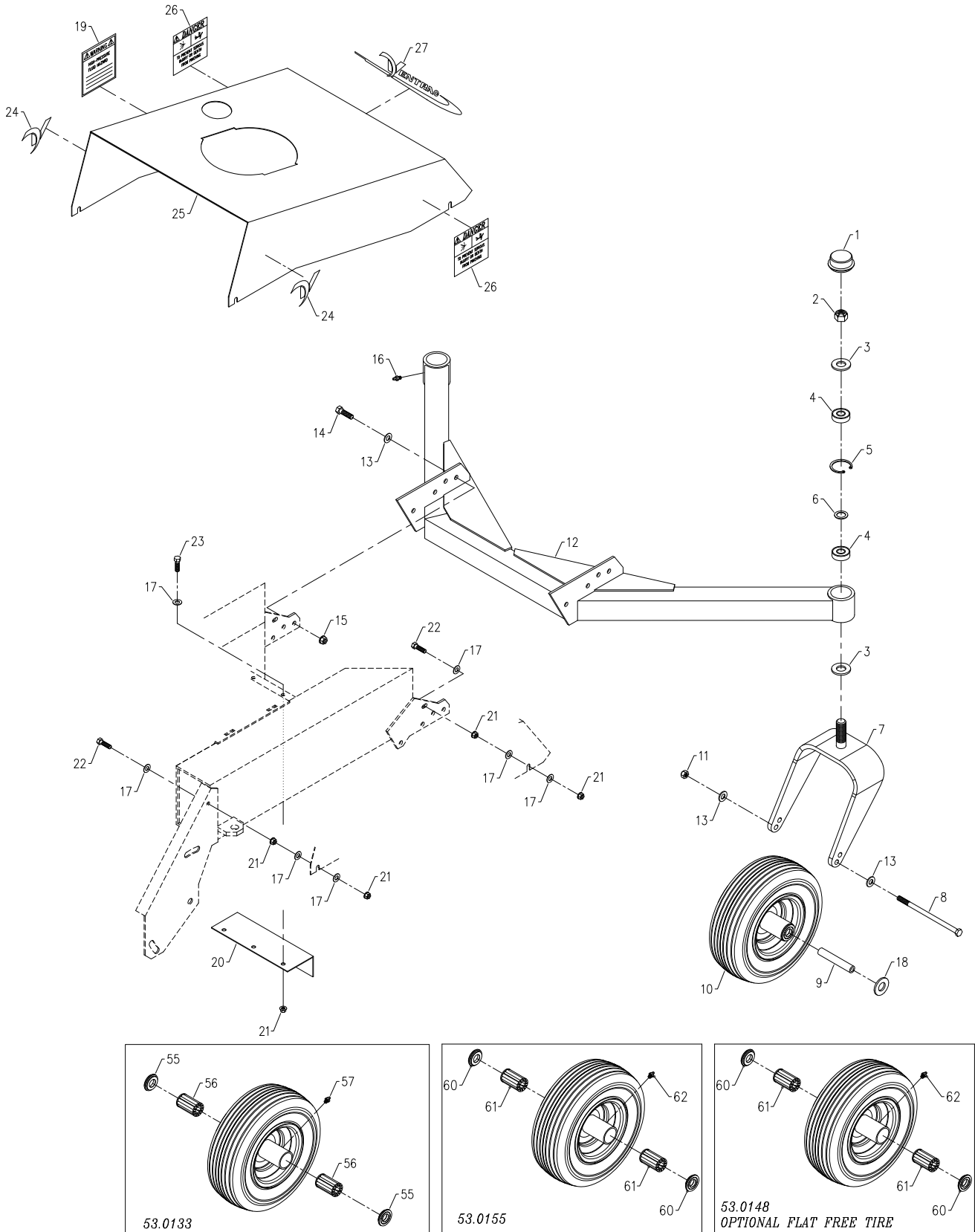

PARTS

Wheel Frame & Shields

REF.	PART NO.	DESCRIPTION	QTY.
1	53.0080	.DUST CAP, BEARING MOWER CASTER	2
2	99.A12NF	.LOCKNUT, STOVER 3/4-16 SAE	2
3	99.B0057-2	.WASHER, MACH3/4 X1-1/4 10GA ZP	4
4	55.0023	.BEARING, BALL .75 ID X 1.78 OD	4
5	04.0013	.SNAP RING, INT .062 X 1.75	2
6	99.B0052	.SHIM, STEEL 3/4 X 1 X .062	2
7	50.0183	.YOKE, CASTER 13", HIGH/LOW	2
8	90.0660	.BOLT, 3/8-16 USS X 7-1/2	2
9	50.0050	.TUBE, SWIVEL AXLE	2
10	53.0133	.WHEEL, ASM 13 X 5 X 6 CASTER (Serial # 1178-1291)	2
10	53.0155	.WHEEL, ASM 13 X 5 X 6 CASTER (Serial # 1292-)	2
10	53.0148	.WHEEL, ASM 13x5x6 RIB FLATFREE (Optional)	2
11	99.A06C	.LOCKNUT, CENTER 3/8-16	2
12	62.0940	.FRAME, FRONT WHEELS MT	1
13	95.06	.WASHER, FLAT 3/8 SAE	12
14	90.0608	.BOLT, 3/8-16 USS X 1	8
15	99.SF06	.NUT, SRF 3/8-16 USS	8
16	29.GF0001	.GREASE FTG, 1/4 SAE ST	2
17	95.05	.WASHER, FLAT 5/16 SAE	15
18	95.12	.WASHER, FLAT 3/4 SAE	2
19	00.0103	.DECAL, HAZARD-HIGH PRESS.FLUID	1
20	60.0838	.SHIELD, AIR FLOW	1
21	99.SF05	.NUT, SRF 5/16-18 USS	11
22	90.0508	.BOLT, 5/16-18 USS X 1	4
23	90.0506	.BOLT, 5/16-18 USS X 3/4	3
24	00.0192	.DECAL, V-DECAL DIE CUT BLUE	2
25	60.0840	.SHIELD, MAIN TOP COVER	1
26	00.0102	.DECAL, DANGER-PINCHING HAZARD	2
27	00.0189	.DECAL, VENTRAC ORBITAL	1
55	55.0066	.BEARING, RETAINER 3/4"	2
56	55.0065	.BEARING, 3/4 ROLLER 2-1/4" LG	2
57	29.GF0001	.GREASE FTG, 1/4 SAE ST	1
60	55.0072	.BEARING, RETAINER 3/4"	2
61	55.0088	.BEARING, ROLLER REPLACEMENT	2
62	29.GF0001	.GREASE FTG, 1/4 SAE ST	1

PARTS

ILLUSTRATED DRAWING Side Wings, Dirt Flap, & Hydraulic Power Angle

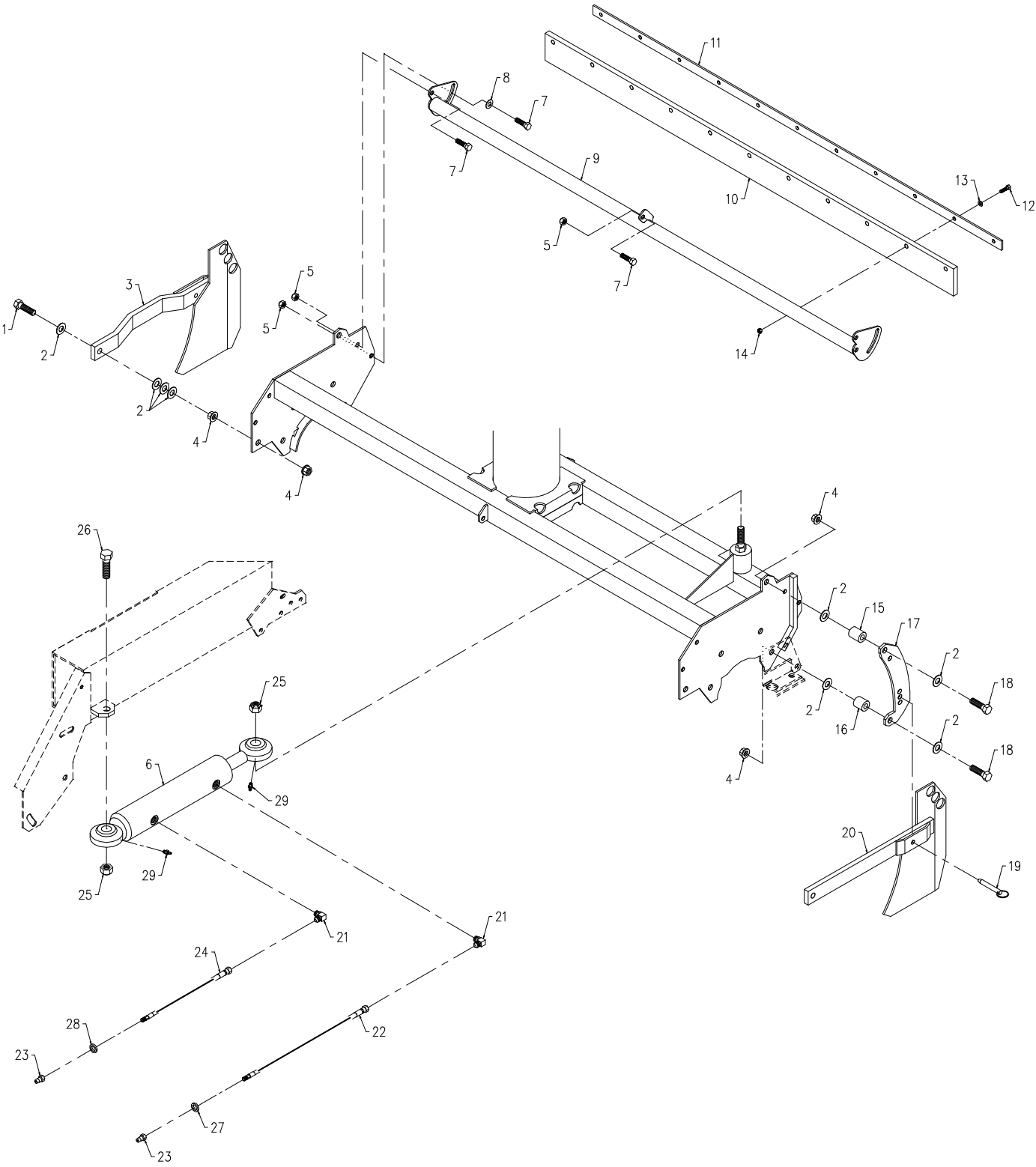

PARTS

Side Wings, Dirt Flap, & Hydraulic Power Angle

REF.	PART NO.	DESCRIPTION	QTY.
1	90.0816	.BOLT, 1/2-13 USS X 2	2
2	95.08	.WASHER, FLAT 1/2 SAE	16
3	62.0943	.WING, LEFT ARM	1
4	99.SF08	.NUT, SRF 1/2-13 USS	8
5	99.A06	.LOCKNUT, STOVER 3/8-16 USS	5
6	23.0129	.CYLINDER, 1-1/2" X 8" STEERING	1
7	90.0606	.BOLT, 3/8-16 USS X 3/4	5
8	95.06	.WASHER, FLAT 3/8 SAE	2
9	62.0941	.FRAME, RUBBER FLAP MT	1
10	44.0200	.FLAP, RUBBER DIRT RETAINER	1
11	60.0839	.CLAMP, RUBBER FLAP 52"	1
12	90.0510	.BOLT, 5/16-18 USS X 1 1/4	11
13	95.05	.WASHER, FLAT 5/16 SAE	11
14	99.A05	.LOCKNUT, STOVER 5/16-18 USS	11
15	64.0680	.BUSHING, 33/64 X 1 X 1 1/4	2
16	64.1527	.BUSHING, .516" X 1" X 1-1/16"L	2
17	64.1006	.PLATE, WING GUIDE	2
18	90.0820	.BOLT, 1/2-13 USS X 2 1/2	4
19	03.0010	.PIN, BALL 3/8 X 1-1/2	2
20	62.0944	.WING, RIGHT ARM	1
21	25.6801-06-06	.FITTING, 90 ME 3/8 X 3/8	2
22	20.0185	.HOSE, 1/4X48.00 SAE 100R17 AR	1
23	23.0104	.COUPLER, QUICK MALE 1/4	2
24	20.0169	.HOSE, 1/4X38.00 SAE 100R17 AR	1
25	99.A10NF	.LOCKNUT, STOVER 5/8-18 SAE	2
26	91.1018	.BOLT, 5/8-18 SAE X 2 1/4	1
27	05.0117	.WASHER, .544ID X .817 X.14 YEL	1
28	05.0116	.WASHER, .544ID X .817 X.14 RED	1
29	29.GF0001	.GREASE FTG, 1/4 SAE ST	2

WARRANTY



LIMITED WARRANTY - VENTRAC COMMERCIAL EQUIPMENT

Venture Products, Inc., (henceforth referred to as V.P.I.) warrants on the terms and conditions herein, that it will repair, replace, or adjust any part manufactured by Venture Products Inc., and found by Venture Products, Inc., to be defective in material and/or workmanship during the applicable warranty term.

All Ventrac commercial equipment purchased and registered on or after January 1, 2019 will carry a 2-year commercial warranty. The warranty period begins on the date of original customer purchase:

Ventrac Commercial Equipment	Warranty Term
2100 SSV & Attachments	2-year
3000 Series Tractors & Attachments	2-year
4000 Series Tractors & Attachments	2-year

All Ventrac add-on kits and accessories such as: 3-point hitch, 12V front & rear power outlets, foot pedal, dual wheel kit, etc., will be covered under the above warranty periods provided they are installed by an Authorized Ventrac Dealer. This warranty may be transferred and will carry the remainder of the warranty starting from the original purchase/registration date with the dealership and/or V.P.I.

The engine warranty is covered by its respective engine manufacturer. Please refer to the engine manufacturer's warranty statement that is included in the owner's manual.

For warranty consideration on Ventrac commercial equipment, including any defective part, must be returned to an Authorized Ventrac Dealer within the warranty period. The warranty shall extend to the cost to repair or replace (as determined by V.P.I.) the defective part. The expense of pickup and delivery of equipment, service call drive time or any transportation expense incurred for warranty repair is the sole responsibility of the owner and is not covered under warranty by Ventrac and/or V.P.I. Ventrac and V.P.I.'s responsibility in respect to claims is limited to making the required repairs or replacements, and no claim of breach of warranty shall be cause for cancellation or rescission of the contract of sale of any Ventrac equipment. Proof of purchase may be required by the dealer to substantiate any warranty claim. Only warranty work performed and submitted by an Authorized Ventrac Dealer may be eligible for warranty credit.

This warranty extends only to Ventrac commercial equipment operated under normal conditions and properly serviced and maintained. The warranty expressly does NOT cover: (a) any defects, damage or deterioration due to normal use, wear and tear, or exposure; (b) normal maintenance services, such as cleaning, lubrication, oil change; (c) replacement of service items, such as oil, lubricants, spark plugs, belts, rubber hoses, bearings or other items subject to normal service replacement; (d) damage or defects arising out of, or relating to abuse, misuse, neglect, alteration, negligence or accident; (e) repair or replacement arising from operation of, or use of the equipment which is not in accordance with operating instructions as specified in the operator's manual or other operational instructions provided by V.P.I.; (f) repair or replacement arising as a result of any operation from Ventrac equipment that has been altered or modified so as to, in the determination of V.P.I., adversely affect the operation, performance or durability of the equipment or that has altered, modified or affected the equipment so as to change the intended use of the product; (g) repair or replacement necessitated by the use of parts, accessories or supplies, including gasoline, oil or lubricants, incompatible with the equipment or other than as recommended in the operator's manual or other operational instructions provided by V.P.I.; (h) repairs or replacements resulting from parts or accessories which have adversely affected the operation, performance or durability of the equipment; or (i) damage or defects due to or arising out of repair of Ventrac equipment by person or persons other than an authorized Ventrac service dealer or the installation of parts other than genuine Ventrac parts or Ventrac recommended parts.

WARRANTY



LIMITED WARRANTY - VENTRAC COMMERCIAL EQUIPMENT

The sole liability of V.P.I. with respect to this warranty shall be the repair and replacement as set forth herein. V.P.I. shall have no liability for any other cost, loss, or damage. In particular V.P.I. shall have no liability or responsibility for: (i) expenses relating to gasoline, oil, lubricants; (ii) loss, cost or expense relating to transportation or delivery of turf equipment from the location of owner or location where used by owner to or from any Authorized Ventrac Dealer; (iii) travel time, overtime, after hours' time or other extraordinary repair charges or charge relating to repairs or replacements outside of normal business hours at the place of business of an Authorized Ventrac Dealer; (iv) rental of like or similar replacement equipment during the period of any warranty repair or replacement work; (v) any telephone or telegram charges; (vi) loss or damage to person or property other than that covered by the terms of this warranty; (vii) any claims for lost revenue, lost profit or additional cost or expense incurred as a result of a claim of breach of warranty; or (viii) attorney's fees.

The remedies of buyer set forth herein are exclusive and are in lieu of all other remedies. The liability of V.P.I., whether in contract, tort, under any warranty, or otherwise, shall not extend beyond its obligation as set forth herein. V.P.I. shall not be liable for cost of removal or installation nor shall V.P.I. be responsible for any direct, indirect, special or consequential damages of any nature. In no event shall V.P.I. be liable for any sum in excess of the price received for the goods for which liability is claimed.

There are no representations or warranties which have been authorized to the buyer of the Ventrac commercial equipment other than set forth in this warranty. Any and all statements or representations made by any seller of this equipment, including those set forth in any sales literature or made orally by any sales representative, are superseded by the terms of this warranty. Any affirmation of fact or promise made by V.P.I. or any of its representatives to the buyer which relates to the goods that are the subject to this warranty shall not be regarded as part of the basis of the bargain and shall not be deemed to create any express warranty that such goods shall conform to the affirmation or promise.

No employee, distributor, or representative is authorized to change the foregoing warranties in any way or grant any other warranty on behalf of V.P.I.

Some states do not allow limitations on how long an implied warranty lasts or allow the exclusion on limitation of incidental or consequential damages, so the above limitation or exclusion may not apply to you.

This warranty gives you specific legal rights, and you may also have other rights which vary from state to state.

This warranty applies to all Ventrac commercial equipment sold by Venture Products Inc.