



Operator's Manual

Canopy



Reader Comments

Ventrac maintains a continuous effort to improve the quality and usefulness of its publications. To do this effectively, we encourage user feedback. Please comment on the completeness, accuracy, organization, usability, and readability of this manual by an email to techpubs@ventrac.com.

or Mail to:

**Technical Publications, Service
Ventrac by Venture Products Inc.®
500 Venture Drive Orrville, OH 44667**

Phone: 1-866-836-8722

Table of Contents

Chapter 1: Introduction	1-1
Intended Use	1-2
Product Description	1-2
Getting Help	1-2
Why do I Need an Operator's Manual?	1-2
Manual Conventions	1-3
Safety Alert Classifications	1-3
Chapter 2: Safety	2-1
General Safety	2-2
Training Required	2-2
Operation Safety	2-2
Maintenance Safety	2-5
Canopy Safety	2-7
Chapter 3: Setup	3-1
Before Setup	3-2
Installing the Roll Bar Lock Brackets	3-3
Installing the Canopy	3-5
Chapter 4: Product Overview	4-1
Attachments/Accessories	4-2
Operational Controls	4-3
Optional Fan Switch	4-3
Optional Light Switches	4-3
Chapter 5: Operation	5-1
Before Operation	5-2
Daily Inspection	5-2
Chapter 6: Maintenance	6-1
Cleaning and Maintaining the Canopy	6-2
Chapter 7: Warranty	7-1
Limited Warranty — Ventrac Commercial Equipment	7-2



Table of Contents

Intended Use	1-2
Product Description	1-2
Getting Help	1-2
Why do I Need an Operator's Manual?	1-2
Manual Conventions	1-3
Safety Alert Classifications	1-3

Intended Use

The Ventrac canopy is intended to only be used with Ventrac 4500, 4520, and 45RC traction units.

Read and Understand the traction unit *Operator's Manual* before operating the machine.

Product Description

The canopy attaches to the Ventrac traction unit, offering shade for the operator and protection from the elements. Optional features include a 3-speed downdraft fan kit to keep the operator cool, a strobe light kit with lights at all four corners of the canopy, and a front work light kit

Note: The traction unit must be equipped with a work light kit in order for the canopy front work light kit to function.

Getting Help

Visit www.Ventrac.com for product safety and operation training materials, accessory information, help finding a dealer, or to register your product.

Whenever you need service, genuine Ventrac parts, or additional information, contact an Authorized Service Dealer or Ventrac Customer Service and have the model and serial numbers of your product ready.

Why do I Need an Operator's Manual?

This manual has been created to help you gain the important knowledge of what is needed to safely operate and maintain your machine, and to avoid injury and product damage. It is divided into chapters for convenient reference of the appropriate information.

You must read and understand the *Operator's Manual* for each piece of Ventrac equipment you own. Reading the *Operator's Manual* will help you become familiar with each specific piece of equipment. If this manual becomes damaged or unreadable, it should be replaced immediately. Contact your local Ventrac dealer for a replacement.

When using a Ventrac attachment, be sure to read and follow the safety and operating instructions of both the machine and the attachment being used to ensure the safest operation possible.

The information in this manual provides the operator with the safest procedures to operate the machine while getting the maximum use out of the unit. Failure to follow the safety precautions listed in this manual may result in personal injury and/or damage to the equipment.

Manual Conventions

This manual identifies potential hazards and has safety messages identified by the safety-alert symbol, which signals a hazard that may cause serious injury or death if you do not follow the recommended precautions.



This manual uses 2 words to highlight information. **Important** calls attention to special mechanical information and **Note** emphasizes general information worthy of special attention.

Safety Alert Classifications

The safety-alert symbol shown in this manual and on the machine identifies important safety messages that you must follow to prevent accidents.

Safety-alert symbol appears above information that alerts you to unsafe actions or situations and is followed by the word **DANGER**, **WARNING**, or **CAUTION**.



Danger indicates an imminently hazardous situation which, if not avoided, *will* result in death or serious injury.



Warning indicates a potentially hazardous situation which, if not avoided, *could* result in death or serious injury.



Caution indicates a potentially hazardous situation which, if not avoided, *may* result in minor or moderate injury.



Table of Contents

General Safety	2-2
Training Required	2-2
Operation Safety	2-2
Maintenance Safety	2-5
Canopy Safety	2-7

General Safety

Training Required

- The owner of this machine is solely responsible for properly training the operators.
- The owner/operator is solely responsible for the operation of this machine and for the prevention of accidents or injuries occurring to him/herself, other people, or property.
- Do not allow operation or service by children or untrained personnel. Local regulations may restrict the age of the operator.
- Before operating this machine, read the *Operator's Manual* and understand its contents.
- If the operator of the machine cannot understand this manual, then it is the responsibility of this machine's owner to fully explain the material within this manual to the operator.
- Learn and understand the use of all the controls.
- Know how to stop the machine and the attachments quickly in the event of an emergency.

Operation Safety

- Secure long hair and loose clothing. Do not wear jewelry.
- Inspect the machine before operation. Repair or replace any damaged, worn, or missing parts. Be sure the guards and shields are in proper working condition and are secured in place. Make any necessary adjustments before operating the machine.
- Some pictures in this manual may show shields or covers opened or removed in order to clearly illustrate the instructions. Under no circumstance should the machine be operated without these devices in place.
- Alterations or modifications to this machine can reduce safety and could cause damage to the machine. Do not alter the safety devices or operate with the shields or covers removed.
- Before each use, verify that all the controls function properly and inspect all the safety devices. Do not operate if the controls or safety devices are not in proper working condition.
- Check the parking brake function before operating. Repair or adjust the parking brake if necessary.
- Observe and follow all of the safety decals.
- All the controls are to be operated from the operator's station only.
- Always wear a seat belt if the machine has a roll cage/bar installed and in the upright position.
- Ensure the attachment or accessory is locked or fastened securely to the machine before operating.
- Ensure that all bystanders are clear of the machine and the attachment before operating. Stop the machine if someone enters your work area.

Operation Safety (continued)

- Always be alert to what is happening around you, but do not lose focus on the task you are performing. Always look in the direction the machine is moving.
- Look behind and down before backing up to be sure of a clear path.
- If you hit an object, stop and inspect the machine. Make any necessary repairs before operating the machine again.
- Stop operation immediately at any sign of equipment failure. An unusual noise can be a warning of equipment failure or a sign that maintenance is required. Make any necessary repairs before operating the machine again.
- If equipped with a high/low range feature, never shift between high and low range while on a slope. Always move the machine to level ground and engage the parking brake before shifting range.
- Do not leave the machine unattended while it is running.
- Always park the machine on level ground.
- Always shut off the engine when connecting the attachment drive belt to the machine.
- Never leave the operator's station without lowering the attachment to the ground, engaging the parking brake, shutting off the engine, and removing the ignition key. Make sure all moving parts have come to a complete stop before dismounting.
- Never leave the machine unattended without lowering the attachment to the ground, engaging the parking brake, shutting off the engine, and removing the ignition key.
- Only operate in well-lit conditions.
- Do not operate when there is a risk of lightning.
- Never direct the discharge of any attachment in the direction of people, buildings, animals, vehicles, or other objects of value.
- Never discharge material against a wall or obstruction. The material may ricochet back toward the operator.
- Use extra caution when approaching blind corners, shrubs, trees, or other objects that may obscure your vision.
- Do not run the engine in a building without adequate ventilation.
- Do not touch the engine or the muffler while the engine is running or immediately after stopping the engine. These areas may be hot enough to cause a burn.
- Do not change the engine governor settings or over-speed the engine. Operating the engine at excessive speeds may increase the hazard of personal injury.
- To reduce the hazard of fire, keep the battery compartment, engine, and muffler areas free of grass, leaves, excessive grease, and other flammable materials.
- Clear the working area of objects that might be hit or thrown from the machine.
- Keep people and pets out of the working area.
- Know the work area well before operation. Do not operate where traction or stability is questionable.
- Reduce speed when you are operating over rough ground.

Operation Safety (continued)

- Equipment can cause serious injury and/or death when improperly used. Before operating, know and understand the operation and safety of the machine and the attachment being used.
- Do not operate the machine if you are not in good physical and mental health, if you will be distracted by personal devices, or if you are under the influence of any substance which might impair your decisions, dexterity, or judgment.
- Children are attracted to machine activity. Be aware of children and do not allow them in the work area. Turn off the machine if a child enters the work area.
- Machines, attachments, and accessories are not designed or intended for travel on public roadways. Never operate or travel on public roads or highways.
- Operate with safety lights when operating near roadways.
- Slow down and be careful of traffic when operating near or crossing roadways. Stop before crossing roads or sidewalks. Use care when approaching areas or objects that may obscure vision.
- Only allow the operator on the machine. Keep riders off.
- Never allow riders on any attachment or accessory.

Requirements for Personal Protective Equipment (PPE)

The owner is responsible for ensuring that all the operators use the proper PPE while operating the machine. Whenever you use the machine, use the following PPE:

- Certified eye protection and hearing protection.
- Closed toe, slip resistant footwear.
- Long pants or trousers.
- A dust mask for dusty conditions.
- Additional PPE may be required. Refer to the product safety procedures for any additional requirements.

Operating On Slopes

- Slopes can cause loss-of-control and tip-over accidents, which can result in severe injury or death. Be familiar with the emergency parking brake, along with the machine controls and their functions.
- If the machine is equipped with a fold down roll bar, it must be locked in the upright position when operating on any slope.
- Use low range (if equipped) when operating on slopes greater than 15 degrees.
- Do not stop or start suddenly when operating on slopes.
- Never shift between high and low range while on a slope. Always move the machine to level ground and engage the parking brake before shifting range or placing the machine in neutral.
- Variables such as wet surfaces and loose ground will reduce the degree of safety. Do not drive where the machine could lose traction or tip over.
- Keep alert for hidden hazards in the terrain.

Operation Safety (continued)

- Stay away from drop-offs, ditches, and embankments.
- Sharp turns should be avoided when operating on slopes.
- Pulling loads on hills decreases safety. It is the responsibility of the owner/operator to determine loads that can safely be controlled on slopes.
- Transport the machine with the attachment lowered or close to the ground to improve stability.
- Attachments and accessories may affect the stability of the traction unit. Refer to the attachment safety section of the attachment *Operator's Manual* for restrictions on the maximum angle of operation.
- While operating on slopes, drive in an up and down direction whenever possible. If turning is necessary while driving across slopes, reduce your speed and turn slowly in the downhill direction.
- Ensure a sufficient supply of fuel for continuous operation. A minimum of one-half tank of fuel is recommended.

Maintenance Safety

- Keep the safety decals legible. Remove all grease, dirt, and debris from the safety decals and instructional labels.
- If any decals are faded, illegible, or missing, contact your dealer promptly for replacements.
- When new components are installed, be sure that the current safety decals are affixed to the replacement components.
- If any component requires replacement, use only original Ventrac replacement parts.
- Always turn the battery disconnect to the OFF position or disconnect the battery before performing any repairs. Disconnect the negative terminal first and the positive terminal last. Reconnect the positive terminal first and the negative terminal last.
- Keep all bolts, nuts, screws, and other fasteners properly tightened.
- Always lower the attachment to the ground, engage the parking brake, shut off the engine, and remove the ignition key. Make sure all moving parts have come to a complete stop before cleaning, inspecting, adjusting, or repairing.
- If the machine, attachment, or accessory requires repairs or adjustments not instructed in the operator's manual, the machine, attachment, or accessory must be taken to an authorized Ventrac dealer for service.
- Never perform maintenance on the machine and/or attachment if someone is in the operator's station.
- Always use protective glasses when handling the battery.
- Check the fuel lines for tightness and wear on a regular basis. Tighten or repair them as needed.
- To reduce the hazard of fire, keep the battery compartment, engine, and muffler areas free of grass, leaves, and excess grease.

Maintenance Safety (continued)

- Do not touch the engine, the muffler, or other exhaust components while the engine is running or immediately after stopping the engine. These areas may be hot enough to cause a burn.
- Allow the engine to cool before storing and do not store near an open flame.
- Do not change the engine governor settings or over-speed the engine. Operating engine at excessive speeds may increase the hazard of personal injury.
- Springs may contain stored energy. Use caution when disengaging or removing springs and/or spring-loaded components.
- An obstruction or blockage in a drive system or moving/rotating parts may cause a buildup of stored energy. When the obstruction or blockage is removed, the drive system or moving/rotating parts may move suddenly. Do not attempt to remove an obstruction or blockage with your hands. Keep your hands, feet, and clothing away from all power-driven parts.

Canopy Safety

The canopy reduces the slope rating of the traction unit by 5 degrees. Refer the traction unit *Operator's Manual* for the machine slope rating and slope operation information.



Table of Contents

Before Setup	3-2
Installing the Roll Bar Lock Brackets	3-3
Installing the Canopy.....	3-5

Before Setup

If you are also installing kits that require routing the wire harness inside the roll bar, refer to the kit instructions and route the wire harness through the roll bar before proceeding with the canopy installation.

If the machine is equipped with a roll bar mounted strobe light, the strobe light must be removed before installing the canopy. The wire harness for the strobe light can be left in place and reused if installing a canopy strobe light kit.

If the machine is equipped with rear work lights, the work lights must be removed from the roll bar, but can be reinstalled on the mount plates^① for the roll bar canopy mount frame.

Note: If the mounting stud on the work light does not fit in the mounting hole in the canopy mount plate^①, either drill the hole to fit the light stud or replace the canopy mount plates with the mount plates from the original rear work light kit.



G545307

Installing the Roll Bar Lock Brackets

Parts Required

Part Number	Quantity	Description
KN-1339	2	Plate, Roll Bar Lock
KN-6053	1	Bracket, Roll Bar Lock RH
KN-6055	1	Bracket, Roll Bar Lock LH
KN-1338	2	Spacer, 1/2 ID x 1-1/8 OD x 3/8 T
90.0512-2	2	Bolt, 5/16-18 x 1-1/2 Tap
99.SF05	4	Nut, SRF 5/16-18 USS
90.0810	2	Bolt, 1/2-13 USS x 1-1/4
90.0814	4	Bolt, 1/2-13 USS x 1-3/4
90.0822	2	Bolt, 1/2-13 USS x 2-3/4
95.08	18	Washer, Flat 1/2 SAE
99.E0103	2	Nut, Locking Flange 1/2-13
99.SF08	6	Nut, SRF 1/2-13 USS

1. Remove the roll bar locking pins^① and the rubber bumpers^② from both hinge points on the roll bar.



2. Thread a 5/16 inch flange nut^③ backward onto a fully threaded 5/16 x 1-1/2 inch bolt^④.
3. Place a 5/16 inch flange nut^⑤ into a roll bar lock plate^⑥ and place the plate into the roll bar bracket. Insert the 5/16 x 1-1/2 inch bolt up through the bracket and thread into the flange nut^⑤. Do not thread the bolt past the top of the flange nut.
4. Remove the pivot bolt, washers, and lock nut from the right roll bar hinge.

5. Insert a 1/2 inch flat washer^⑦ between the upper and lower roll bar hinge plates. Install the right roll bar lock bracket onto the right roll bar hinge using a 1/2 x 1-3/4 inch bolt^⑧ and flat washer. Secure with a flange nut but do not tighten.

Note: if there is a gap between the lock bracket and the hinge plate, use a 1/2 inch flat washer^⑨ as a spacer to fill the gap.

6. Insert a 1/2 x 1-1/4 inch bolt^⑩ and flat washer through the lower mounting hole using a 1/2 inch flat washer^⑨ between the lock bracket and the hinge plate if necessary. Secure with a flange nut but do not tighten.
7. Place a 3/8 inch thick spacer^⑪ between the lock bracket and the upper hinge plate, along with a 1/2 inch flat washer^⑨ if necessary. Insert a 1/2 x 1-3/4 inch bolt^⑫ and flat washer through the upper mounting hole. Secure with a flange nut but do not tighten.

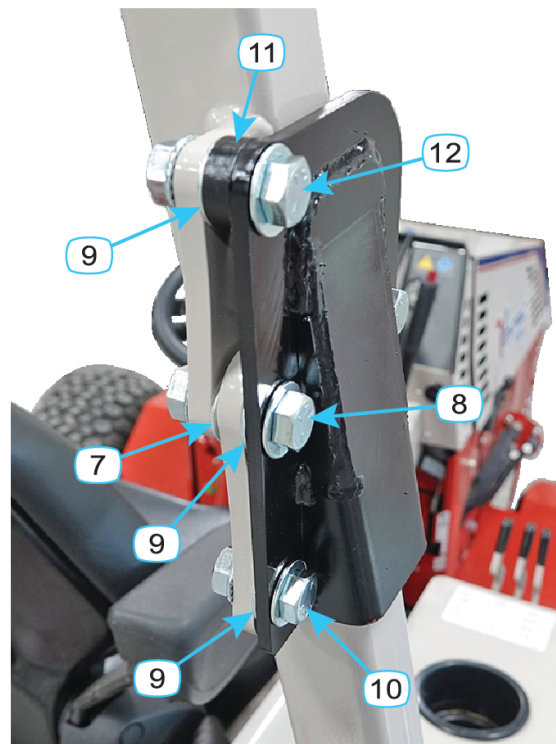

G545903

8. Insert a 1/2 x 2-3/4 inch bolt^⑬ and flat washer through the front mounting hole in the lock bracket using a 1/2 inch flat washer^⑭ between the lock bracket and the roll bar plate if necessary. Secure with a 1/2 inch locking flange nut and tighten only until snug.
9. Tighten the 5/16 inch bolt^④ to lock the upper roll bar against the 1/2 inch bolt^⑬, then tighten the flange nut^③ to secure.
10. Torque the three rear mounting bolts^⑧, ^⑩, ^⑫ on the lock bracket to 102 N·m (75 ft-lb).
11. Repeat these steps to install the left roll bar lock bracket.

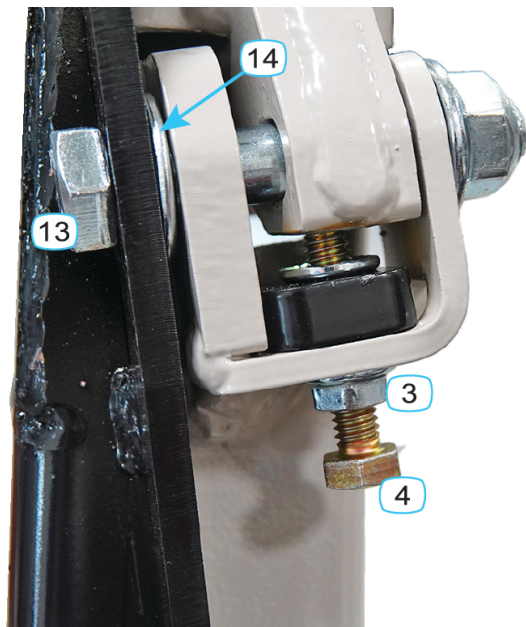

G545989

Installing the Canopy

Parts Required

Part Number	Quantity	Description
—	1	Canopy Assembly
—	1	Roll Bar Mount Assembly
KN-1222	2	Mount, Canopy Frame
KN-1225	2	Plate, Roll Bar Mount
42.0608	2	Link, Rod Assembly 20.00"
11.0053	4	U-Bolt, 3/8–16 2–1/16 ID SQ Bend
90.0820	6	Bolt, 1/2–13 USS x 2–1/2
95.08	2	Washer, Flat 1/2 SAE
99.B0141	6	Washer, Fender 1/2" x 1–3/4" OD
99.E0103	6	Nut, Locking Flange 1/2–13
99.E0136	8	Nut, Locking Flange 3/8–16
99.SF06	4	Nut, SRF 3/8–16 USS
99.SF0606–1	4	Bolt, SMF 3/8–16 USS x 3/4

1. Place the roll bar mount frame onto the top of the roll bar. Install two U-bolts^① around the roll bar and through the lower mounting positions on the mount frame. Secure with 3/8 inch locking flange nuts but do not tighten.

Note: The mounting plates include tabs for mounting rear work lights. The tab should be at the rear of the roll bar and the tab can be turned to either the inside or the outside.

2. Install two U-bolts^② over the top of the mount frame and the roll bar. Install the roll bar mount plates^③ onto the U-bolts and secure with 3/8 inch locking flange nuts but do not tighten.
3. Center the mount frame on the roll bar and tighten the eight 3/8 inch locking flange nuts evenly on the U-bolts until they are torqued to 42 N·m (31 ft-lb).

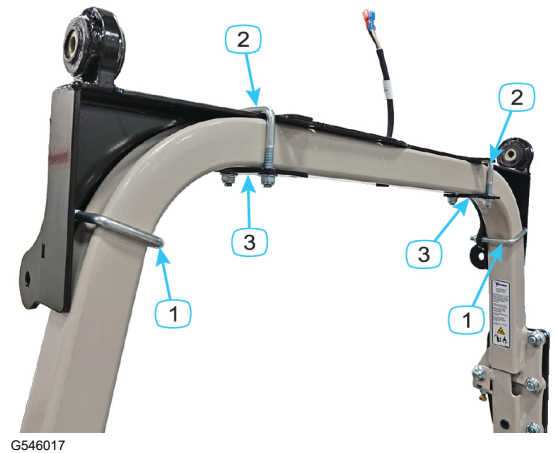

4. Install the support arms⁽⁴⁾ onto the roll bar mount frame using 1/2 x 2-1/2 inch bolts⁽⁵⁾ with 1/2 x 1-3/4 inch fender washers⁽⁶⁾. Secure with locking flange nuts but do not tighten.

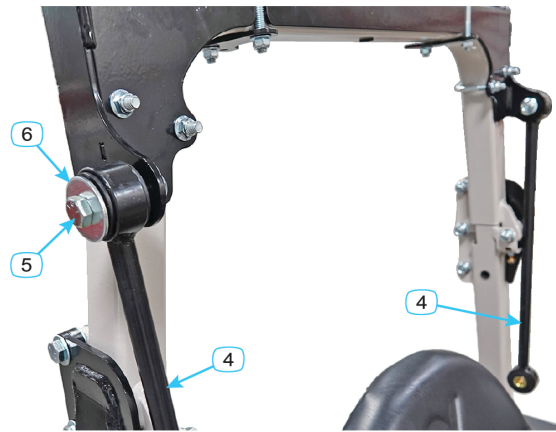

G546019

Note: There are two mounting positions on the canopy frame mounts. The standard position uses the lower set of mounting holes. For a taller operator, the canopy frame mounts may need to be mounted using the upper mounting holes⁽⁸⁾.

5. Install the canopy frame mounts⁽⁷⁾ onto the canopy frame using 3/8 x 3/4 inch flange bolts and flange nuts. Torque to 42 N·m (31 ft-lb).

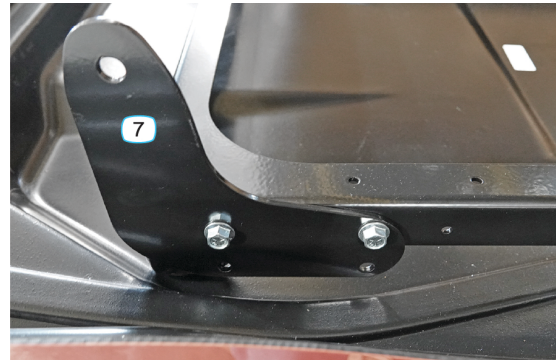

G546021

6. Have a helper to assist in lifting the canopy into position. Insert 1/2 x 2-1/2 inch bolts and flat washers through the canopy frame mounts and the rubber bushings in the roll bar frame mount. Install 1/2 x 1-3/4 inch fender washers⁽⁹⁾ on the inside of the rubber bushings and secure with locking flange nuts⁽¹⁰⁾ but do not tighten.



G546077

7. Install the support arms onto the canopy frame using 1/2 x 2-1/2 inch bolts⁽¹¹⁾ with 1/2 x 1-3/4 inch fender washers⁽¹²⁾. If the canopy frame mounts are installed in the standard (low) position, the support arms mount in the front mounting holes. If the canopy frame mounts are installed in the high position⁽¹³⁾, the support arms mount in the rear mounting holes⁽¹⁴⁾. Secure with locking flange nuts.

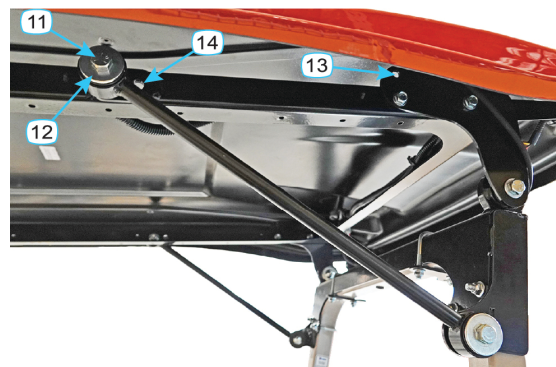

G546089

8. Torque the four support arm bolts and the two frame mount bolts to 102 N·m (75 ft-lb).

IMPORTANT

If the protective film is left on the canopy roof, it may become extremely difficult to remove at a later time.

9. Remove the protective film from the canopy roof.

Installation is complete.



Table of Contents

Attachments/Accessories	4-2
Operational Controls	4-3
Optional Fan Switch	4-3
Optional Light Switches	4-3

Attachments/Accessories

A selection of Ventrac approved attachments and accessories is available for use with the machine to enhance and expand its capabilities. Contact your Authorized Service Dealer or authorized Ventrac distributor or go to www.Ventrac.com for a list of all approved attachments and accessories.

To ensure optimum performance and continued safety certification of the machine, use only genuine Ventrac replacement parts and accessories.

Operational Controls

Optional Fan Switch

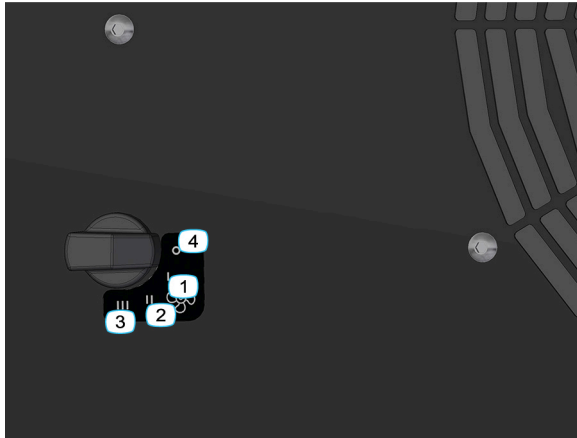

Rotate the fan switch to select Low^①, Medium^②, or High^③ speed. Rotate the switch to the OFF position^④ to turn off the fan.

Optional Light Switches

Refer to the traction unit *Operator's Manual* for the locations of the strobe light and work light switches.



Table of Contents

Before Operation.....	5-2
Daily Inspection.....	5-2

Before Operation

Daily Inspection



WARNING



Always engage the parking brake, shut off the traction unit engine, remove the ignition key, and ensure that all moving parts have come to a complete stop before inspecting the components, or attempting any repair or adjustment. Failure to do so can result in injury or death.

1. Park the machine on a level surface, engage the parking brake, and remove the key from the ignition.
2. Inspect the traction unit in accordance with the traction unit *Operator's Manual*.
3. Perform a visual inspection of the canopy. Replace any missing or damaged components before operating the machine.



Table of Contents

Cleaning and Maintaining the Canopy 6-2

Cleaning and Maintaining the Canopy



WARNING



Always engage the parking brake, shut off the traction unit engine, remove the ignition key, and ensure that all moving parts have come to a complete stop before inspecting the components, or attempting any repair or adjustment. Failure to do so can result in injury or death.

IMPORTANT

If any component requires replacement, use only original Ventrac replacement parts.

1. Clean or wash the canopy after each use to remove dust, grass clippings, and other debris.
2. Inspect the painted components for chips, scratches, or rust. Clean and touch up the surfaces as needed.



Table of Contents

Limited Warranty — Ventrac Commercial Equipment..... 7-2

Limited Warranty — Ventrac Commercial Equipment

Venture Products, Inc., (henceforth referred to as V.P.I.) warrants on the terms and conditions herein, that it will repair, replace, or adjust any part manufactured by V.P.I., and found by V.P.I., to be defective in material and/or workmanship during the applicable warranty term.

All Ventrac commercial equipment purchased on or after January 1, 2019, will carry a 2-year commercial warranty. The warranty period begins on the date of original customer purchase:

Ventrac Commercial Equipment	Warranty Term
2000 Series SSV's and Attachments	2-year
3000 Series Tractors and Attachments	2-year
4000 Series Tractors and Attachments	2-year

All Ventrac add-on kits and accessories such as: 3-point hitch, 12V front & rear power outlets, foot pedal, dual wheel kit, etc., will be covered under the above warranty periods provided they are installed by an Authorized Ventrac Dealer. This warranty may be transferred and will carry the remainder of the warranty starting from the original purchase/registration date with the dealership and/or V.P.I.

The engine warranty is covered by its respective engine manufacturer. Please refer to the engine manufacturer's warranty statement that is included in the owner's manual.

For warranty consideration, the Ventrac commercial equipment, including any defective part, must be returned to an Authorized Ventrac Dealer within the warranty period. The warranty shall extend to the cost to repair or replace (as determined by V.P.I.) the defective part. The expense of pickup and delivery of equipment, service call drive time or any transportation expense incurred for warranty repair is the sole responsibility of the owner and is not covered under warranty by Ventrac and/or V.P.I. Ventrac and V.P.I.'s responsibility in respect to claims is limited to making the required repairs or replacements, and no claim of breach of warranty shall be cause for cancellation or rescission of the contract of sale of any Ventrac equipment. Proof of purchase may be required by the dealer to substantiate any warranty claim. Only warranty work performed and submitted by an Authorized Ventrac Dealer may be eligible for warranty credit.

This warranty extends only to Ventrac commercial equipment operated under normal conditions and properly serviced and maintained. The warranty expressly does NOT cover: (a) any defects, damage or deterioration due to normal use, wear and tear, or exposure; (b) normal maintenance services, such as cleaning, lubrication, oil change; (c) replacement of service items, such as oil, lubricants, spark plugs, belts, rubber hoses, bearings or other items subject to normal service replacement; (d) damage or defects arising out of, or relating to abuse, misuse, neglect, alteration, negligence or accident; (e) repair or replacement arising from operation of, or use of the equipment which is not in accordance with operating instructions as specified in the operator's manual or other operational instructions provided by V.P.I.; (f) repair or replacement arising as a result of any operation from Ventrac equipment that has been altered or modified so as to, in the determination of V.P.I., adversely affect the operation,

performance or durability of the equipment or that has altered, modified or affected the equipment so as to change the intended use of the product; (g) repair or replacement necessitated by the use of parts, accessories or supplies, including gasoline, oil or lubricants, incompatible with the equipment or other than as recommended in the operator's manual or other operational instructions provided by V.P.I.; (h) repairs or replacements resulting from parts or accessories which have adversely affected the operation, performance or durability of the equipment; or (i) damage or defects due to or arising out of repair of Ventrac equipment by person or persons other than an authorized Ventrac service dealer or the installation of parts other than genuine Ventrac parts or Ventrac recommended parts.

The sole liability of V.P.I. with respect to this warranty shall be the repair and replacement as set forth herein. V.P.I. shall have no liability for any other cost, loss, or damage. In particular V.P.I. shall have no liability or responsibility for: (i) expenses relating to gasoline, oil, lubricants; (ii) loss, cost or expense relating to transportation or delivery of turf equipment from the location of owner or location where used by owner to or from any Authorized Ventrac Dealer; (iii) travel time, overtime, after hours' time or other extraordinary repair charges or charge relating to repairs or replacements outside of normal business hours at the place of business of an Authorized Ventrac Dealer; (iv) rental of like or similar replacement equipment during the period of any warranty repair or replacement work; (v) any telephone or data charges; (vi) loss or damage to person or property other than that covered by the terms of this warranty; (vii) any claims for lost revenue, lost profit or additional cost or expense incurred as a result of a claim of breach of warranty; or (viii) attorney's fees.

The remedies of buyer set forth herein are exclusive and are in lieu of all other remedies. The liability of V.P.I., whether in contract, tort, under any warranty, or otherwise, shall not extend beyond its obligation as set forth herein. V.P.I. shall not be liable for cost of removal or installation nor shall V.P.I. be responsible for any direct, indirect, special or consequential damages of any nature. In no event shall V.P.I. be liable for any sum in excess of the price received for the goods for which liability is claimed.

All implied warranties, including merchantability and fitness for a particular purpose, are limited to the duration of the express warranty.

There are no representations or warranties which have been authorized to the buyer of the Ventrac commercial equipment other than set forth in this warranty. Any and all statements or representations made by any seller of this equipment, including those set forth in any sales literature or made orally by any sales representative, are superseded by the terms of this warranty. Any affirmation of fact or promise made by V.P.I. or any of its representatives to the buyer which relates to the goods that are the subject to this warranty shall not be regarded as part of the basis of the bargain and shall not be deemed to create any express warranty that such goods shall conform to the affirmation or promise.

No employee, distributor, or representative is authorized to change the foregoing warranties in any way or grant any other warranty on behalf of V.P.I.

Some states do not allow limitations on how long an implied warranty lasts or allow the exclusion on limitation of incidental or consequential damages, so the above limitation or exclusion may not apply to you.

This warranty gives you specific legal rights, and you may also have other rights which vary from state to state.

This warranty applies to all Ventrac commercial equipment sold by Venture Products Inc.