

Parts Manual

EA600

Aera-Vator



Revised 10/07/24
09.20027 Rev. 03



500 Venture Drive
Orrville Oh 44667
www.ventrac.com

Serial Number Description



Notes

- If any component requires replacement, use only original Ventrac replacement parts.
- When ordering new components, be sure to order all required safety decals. All current safety decals must be affixed to the replacement components prior to installation of the component.

TABLE OF CONTENTS

PARTS	PAGE 4
Main Frame & Shields.....	4
Gearbox & Drive Shaft.....	6
Drive Clutch.....	8
Rotor Shaft Assembly, 16 Tine (Serial # 1001-1139).....	10
Rotor Shaft Assembly, 24 Tine (Serial # 1140-).....	12
OPTIONS	PAGE 14
70.8014 Optional Rear Roller Kit.....	14
70.8015 Seeder Kit Mount & Motor.....	16
70.8015 Seeder Kit Hopper & Controls.....	18

PARTS

ILLUSTRATED DRAWING Main Frame & Shields

SERIAL # 1001-1076

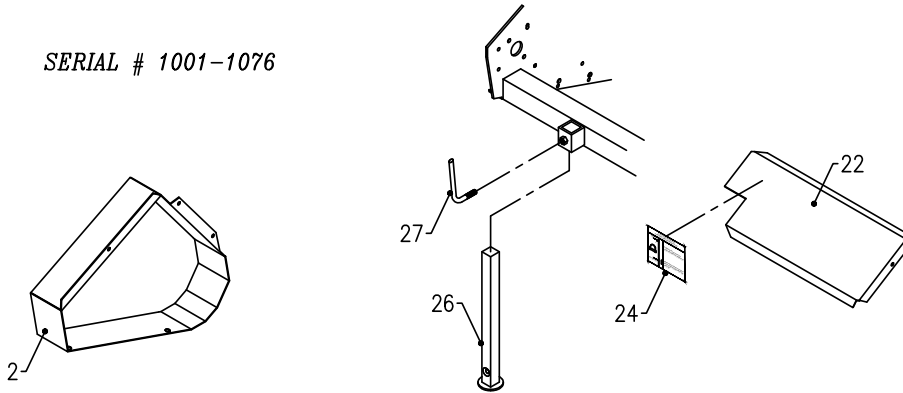

SERIAL # 1077 --

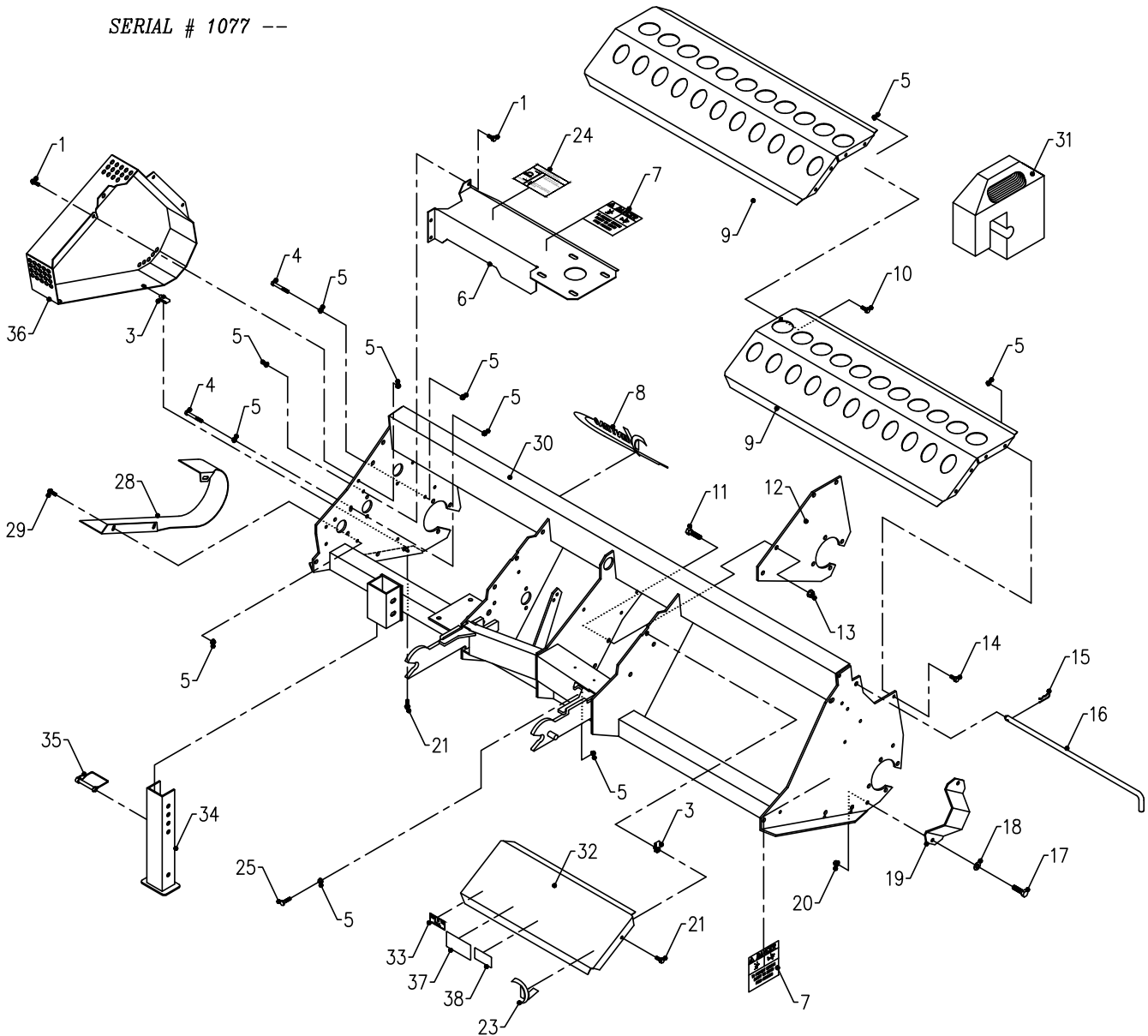

PARTS

Main Frame & Shields

REF.	PART NO.	DESCRIPTION	QTY.
1	99.SF0404-1	.BOLT, SMF 1/4-20 X 1/2	6
2	60.0853	.SHIELD, 3-BELT END EA	1
3	99.E0046	.NUT,"U" 1/4-20 EXTRUDED	4
4	90.0428	.BOLT, 1/4-20 USSX31/2	2
5	99.SF04	.NUT, SRF 1/4-20 USS	24
6	60.0851	.SHIELD, SHAFT	1
7	00.0102	.DECAL, DANGER-PINCHING HAZARD (Serial # 1001-3376)	2
7	00.0624	.DECAL, CUTTING HAZARD HANDS AND FEET (Serial # 3377-)	2
8	00.0189	.DECAL, VENTRAC ORBITAL (Serial # 1001-4312)	1
8	00.0383	.DECAL, VENTRAC (Serial # 4313-)	1
9	60.0850	.SHIELD, ROTOR	2
10	99.SF0406-1	.BOLT, SMF 1/4-20 X 3/4	3
11	90.0606	.BOLT, 3/8-16 USS X 3/4	4
12	64.1051	.MOUNT, BEARING CENTER	1
13	99.SF06	.NUT, SRF 3/8-16 USS	4
14	99.SF0405-1	.BOLT, SMF 1/4-20 X 5/8	6
15	02.HP0416	.HAIRPIN, 1/8 X 2	2
16	42.0457	.ROD, WEIGHT RETAINER	2
17	90.0506	.BOLT, 5/16-18 USS X 3/4	2
18	95.05	.WASHER, FLAT 5/16 SAE	2
19	60.0855	.SHIELD, ROTOR END RIGHT SIDE	1
20	99.SF05	.NUT, SRF 5/16-18 USS	2
21	99.SF0406-1	.BOLT, SMF 1/4-20 X 3/4	4
22	60.0854	.COVER, MID EA	1
23	00.0192	.DECAL, V-DECAL DIE CUT BLUE	1
24	00.0205	.DECAL, CLUTCH DRIVE REL. PIN (Serial # 1001-3376)	1
24	00.0643	.DECAL, CLUTCH DRIVE PIN (Serial # 3377-)	1
25	90.0408	.BOLT, 1/4-20 USS X 1	1
26	62.0957	.STAND, JACK	1
27	40.0309	.HANDLE, JACKSTAND LOC	1
28	64.1054	.RETAINER, BELT	1
29	99.SF0404-1	.BOLT, SMF 1/4-20 X 1/2	3
30	62.0956	.FRAME, MAIN EA600	1
31	47.0115*	.WEIGHT, SUITCASE- 42 LBS W/BOX	8
32	60.0888	.SHIELD, TORSION SPRING	1
33	00.0770	.DECAL, MADE IN USA	1
34	62.1027	.STAND, JACK (no longer available, order 62.1073 for replacement)	1
34	62.1073	.STAND, JACK EA600	1
35	03.0015	.PIN, SAFETY SNAP 3/8 X 3"	1
36	60.0887	.SHIELD, FINAL DRIVE LEFT SIDE	1
37	00.0217	.DECAL, WARNING READ OWNERS MAN (Serial # 1001-3376)	1
37	00.0619	.DECAL, READ OPERATORS MANUAL (Serial # 3377-)	1
38	00.0631	.DECAL, FINGER/HAND ENTANGLEMENT (Serial # 3377-)	1

PARTS

ILLUSTRATED DRAWING Gearbox & Drive Shaft

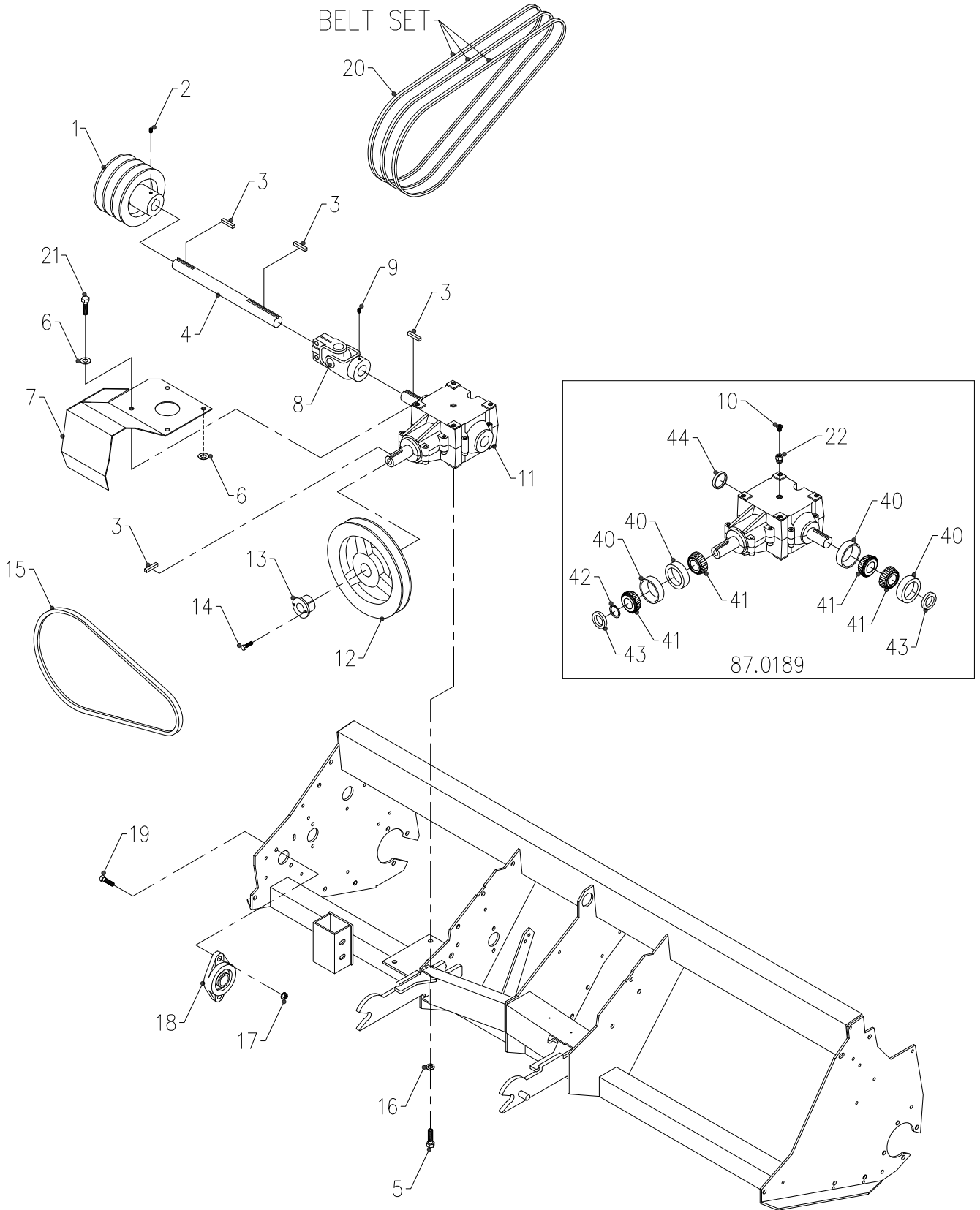

PARTS

Gearbox & Drive Shaft

REF.	PART NO.	DESCRIPTION	QTY.
1	83.3BK3016	PULLEY, 3" 1" BORE 3-GROOVE	1
2	85.SS09	SET SCREW, 5/16"-18 X 3/8"	2
3	85.K0408	KEY, 1/4X1	4
4	80.0330	SHAFT, DRIVE	1
5	90.0608	BOLT, 3/8-16 USS X 1	4
6	95.06	WASHER, FLAT 3/8 SAE	6
7	60.0852	SHIELD, BELT DRIVE	1
8	87.0204	U-JOINT, 1" X 1" WEASLER	1
9	85.SS21	SETSCREW, 3/8-16 X 3/8	2
10	29.0093	PIPE, BREATHER PLUG 1/4	1
11	87.0189	GEARBOX, 1" SHAFT 2:1 CW/CCW	1
12	83.BK70H	PULLEY, 7" H-BUSH	1
13	83.H16S	BUSHING, 1" SPLIT 1/4" KEY	1
14	90.0406	BOLT, 1/4-20 USS X 3/4	2
15	81.B050	BELT,B50	1
16	96.06	WASHER, LOCK 3/8	4
17	99.SF05	NUT, SRF 5/16-18 USS	2
18	55.FB16016-1	BEARING, FLANGE BLOCK 1"	1
19	90.0508	BOLT, 5/16-18 USS X 1	2
20	81.BX038-3	BELT, BX38 MATCHED SET (3)	1
21	90.0606	BOLT, 3/8-16 USS X 3/4	4
22	29.B0204G	PIPE, BUSHING 1/8 X 1/4 GALV	1
40	55.0076	BEARING, CUP 1.980	4
41	55.0075	BEARING, CONE 1.000	4
42	04.0026	RETAINING RING, EXT 1.000 SHFT.	1
43	89.0075	SEAL, OIL	2
44	89.0081	SEAL, END CAP1.50-25	1

PARTS

ILLUSTRATED DRAWING Drive Clutch

SERIAL # 1001-1076

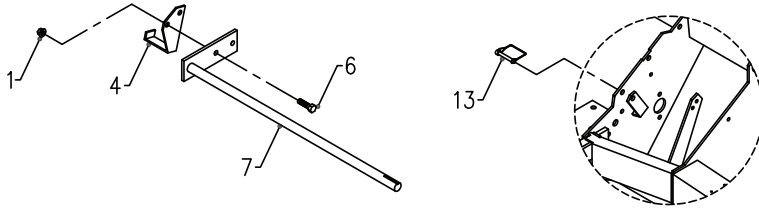

SERIAL # 1077 --

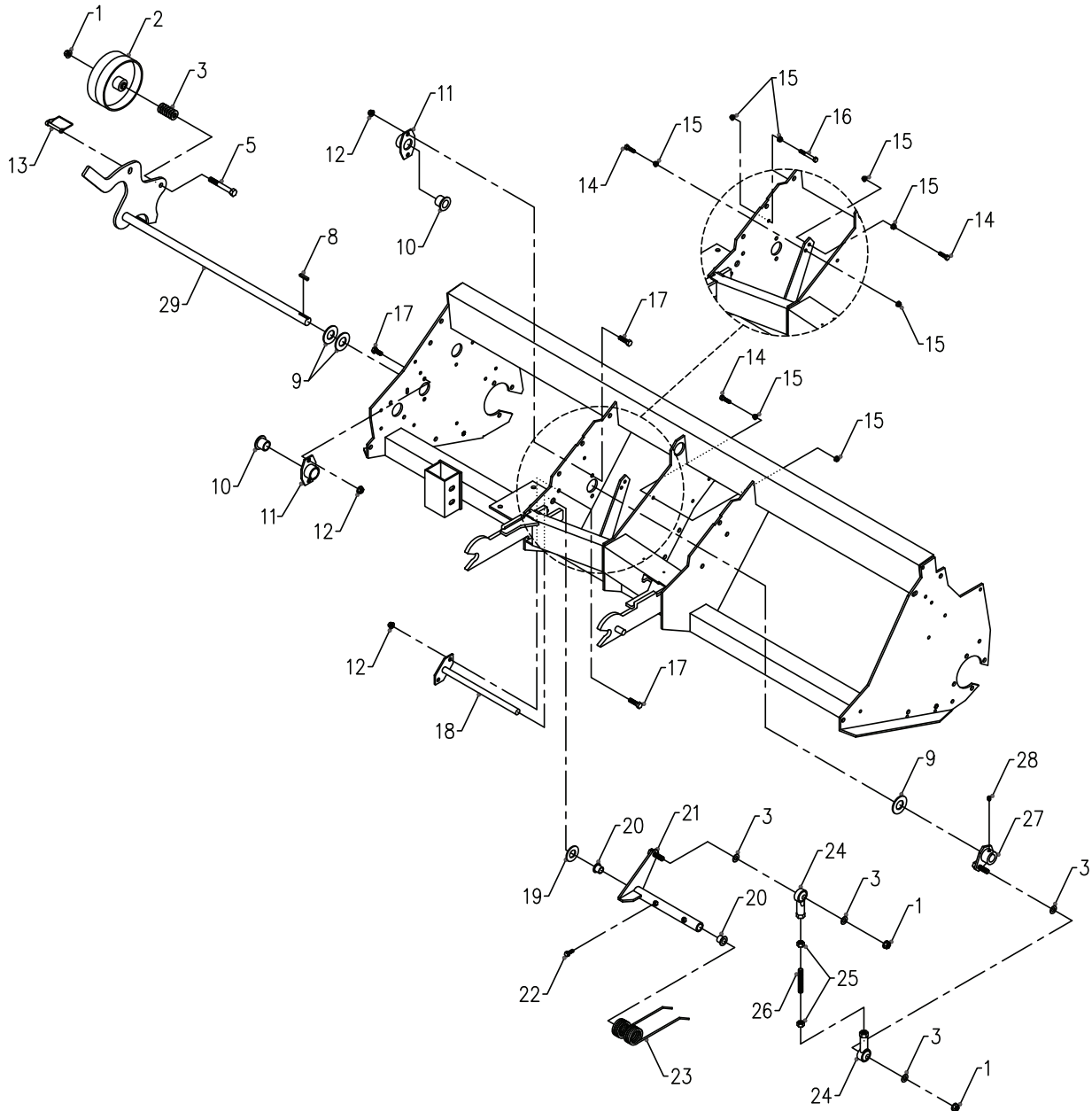

PARTS

Drive Clutch

REF.	PART NO.	DESCRIPTION	QTY.
1	99.SF06	.NUT, SRF 3/8-16 USS.	4
2	83.0045	.PULLEY, IDLER FLAT 6" X 2-1/8	1
3	95.06	.WASHER, FLAT 3/8 SAE	11
4	64.1060	.PLATE,BELT LIFTER	1
5	90.0618	.BOLT, 3/8-16 USSX21/4	1
6	90.0606	.BOLT, 3/8-16 USS X 3/4	1
7	80.0329	.SHAFT, IDLER EA.	1
8	85.K0310	.KEY, 3/16X11/4	1
9	95.12	.WASHER, FLAT 3/4 SAE	3
10	85.B0077	.BUSHING, 3/4 ID X 1" OD X 3/4.	2
11	64.1052	.BRACKET, BEARING EA600	2
12	99.SF05	.NUT, SRF 5/16-18 USS.	6
13	03.0001	.PIN, SAFETY SNAP 3/8 X 1-3/4.	1
14	90.0408	.BOLT, 1/4-20 USS X 1.	3
15	99.SF04	.NUT, SRF 1/4-20 USS.	8
16	90.0420	.BOLT, 1/4-20 USSX21/2	1
17	90.0506	.BOLT, 5/16-18 USS X 3/4	6
18	64.1053	.SHAFT CLUTCH RELEASE PIVOT	1
19	95.08	.WASHER, FLAT 1/2 SAE	1
20	85.B0027	.BUSHING, 1/2 ID X 5/8 OD X 5/8.	2
21	40.0307	.ARM, CLUTCH RELEASE	1
22	99.SF0404	.BOLT, SRF 1/4-20 X 1/2	2
23	41.0065	.SPRING, DOUBLE TORSION BLACK	2
24	43.006	.ROD END, 3/8 SPHERICAL	2
25	93.06	.NUT, 3/8-24 SAE	2
26	42.0458	.ROD, THREADED3/8 24 X 2-1/2"	1
27	40.0308	.HUB CLUTCH SHAFT CONTROL	1
28	85.SS19	.SET SCREW, 1/4-20 X 1/4"	1
29	80.0353	.ARM, BELT TIGHTNER	1

PARTS

ILLUSTRATED DRAWING Rotor Shaft Assembly, 16 Tine (Serial # 1001-1139)

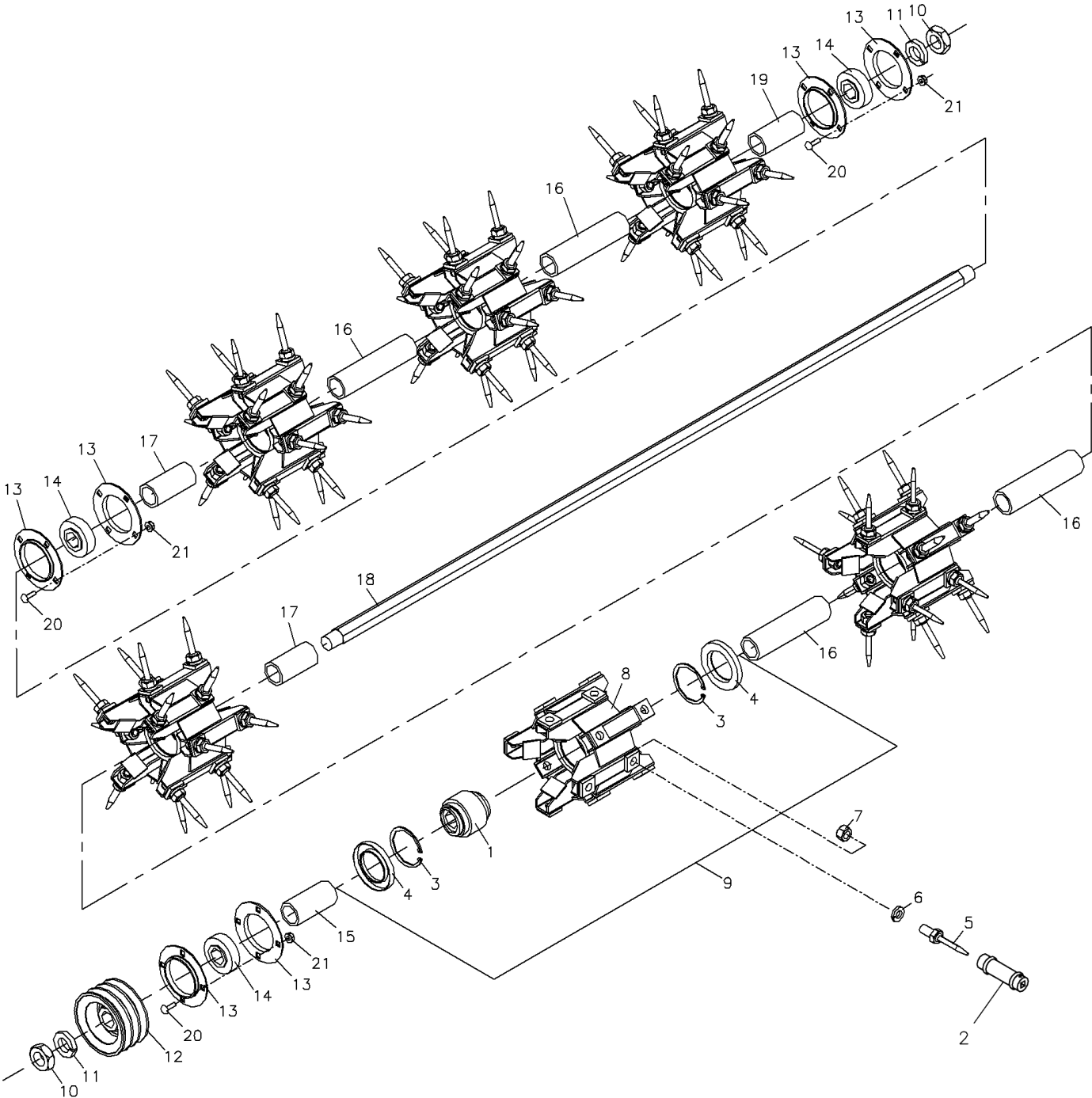

PARTS

Rotor Shaft Assembly, 16 Tine (Serial # 1001-1139)

REF.	PART NO.	DESCRIPTION	QTY.
1	80.0336	.ADAPTER, BEARING 5 DEG	6
2	72.0041	.TOOL, 15/16" EXTRA DEEP SOCKET	1
3	04.0023	.SNAP RING, INT 3"	12
4	89.0071	.SEAL, EXTERNAL ROTOR	12
5	79.0065	.TINE, W/ 5/8" NF STUD	96
6	99.B0079	.WASHER, LOCK 5/8" G8	96
7	93.10	.NUT, 5/8-18 SAE	96
8	80.0366-1	.ROTOR, ONLY SHELL	6
9	80.0366	.ASM, ROTOR (24 TINE) W/O TINES	6
10	99.E0070	.NUT, JAM 1-1/8"-12 SAE G5 ZP	2
11	96.18	.WASHER, LOCK 1 1/8	2
12	83.3TB465	.PULLEY, 3-GROOVE X 4.65 DIA	1
13	55.0054	.FLANGE, 72MM X 4 HOLE	6
14	55.0055	.BEARING, 1 1/8 HEX	3
15	80.0337	.SPACER, DRIVE END 3 51/64"	1
16	80.0338	.SPACER, LONG 7 1/4"	4
17	80.0339	.SPACER, CENTER 3 9/16"	2
18	80.0341	.SHAFT, ROTOR 60"	1
19	80.0340	.SPACER, RIGHT END 3 19/64"	1
20	97.0608	.BOLT, CARRIAGE 3/8 X 1	12
21	99.E0071	.NUT, SRF 3/8-16 USS	12

PARTS

ILLUSTRATED DRAWING Rotor Shaft Assembly, 24 Tine (Serial # 1140-)

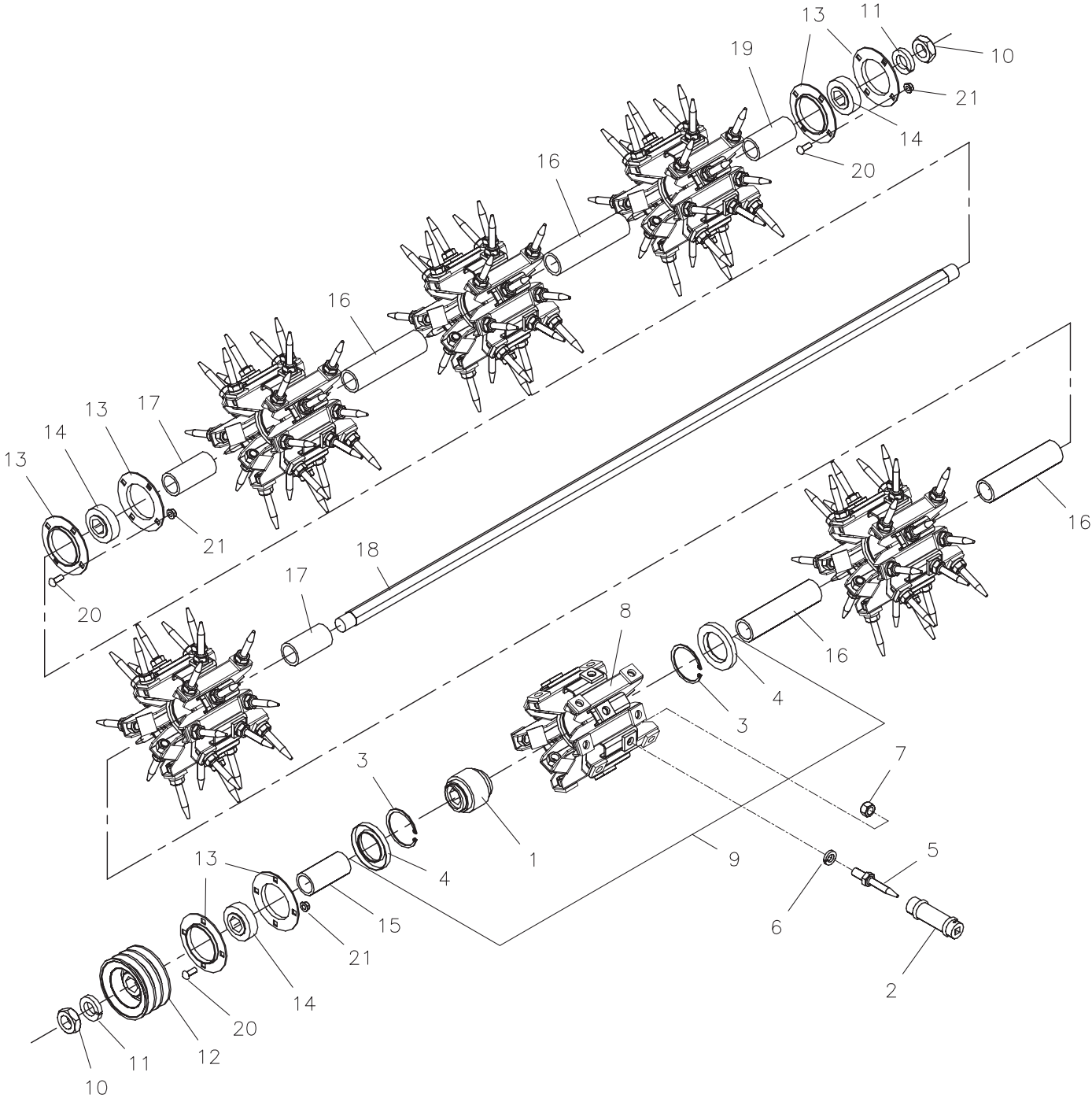

PARTS

Rotor Shaft Assembly, 24 Tine (Serial # 1140-)

REF.	PART NO.	DESCRIPTION	QTY.
1	80.0336	.ADAPTER, BEARING 5 DEG	6
2	72.0041	.TOOL, 15/16" EXTRA DEEP SOCKET	1
3	04.0023	.SNAP RING, INT 3"	12
4	89.0071	.SEAL, EXTERNAL ROTOR	12
5	79.0065	.TINE, W/ 5/8" NF STUD	144
6	99.B0079	.WASHER, LOCK 5/8" G8	144
7	93.10	.NUT, 5/8-18 SAE	144
8	80.0366-1	.ROTOR, ONLY SHELL	6
9	80.0366	.ASM, ROTOR (24 TINE) W/O TINES	6
10	99.E0070	.NUT, JAM 1-1/8"-12 SAE G5 ZP	2
11	96.18	.WASHER, LOCK 1 1/8	2
12	83.3TB465	.PULLEY, 3-GROOVE X 4.65 DIA	1
13	55.0054	.FLANGE, 72MM X 4 HOLE	6
14	55.0055	.BEARING, 1 1/8 HEX	3
15	80.0337	.SPACER, DRIVE END 3 51/64"	1
16	80.0338	.SPACER, LONG 7 1/4"	4
17	80.0339	.SPACER, CENTER 3 9/16"	2
18	80.0341	.SHAFT, ROTOR 60"	1
19	80.0340	.SPACER, RIGHT END 3 19/64"	1
20	97.0608	.BOLT, CARRIAGE 3/8 X 1	12
21	99.E0071	.NUT, SRF 3/8-16 USS	12

OPTIONS

ILLUSTRATED DRAWING 70.8014 Optional Rear Roller Kit

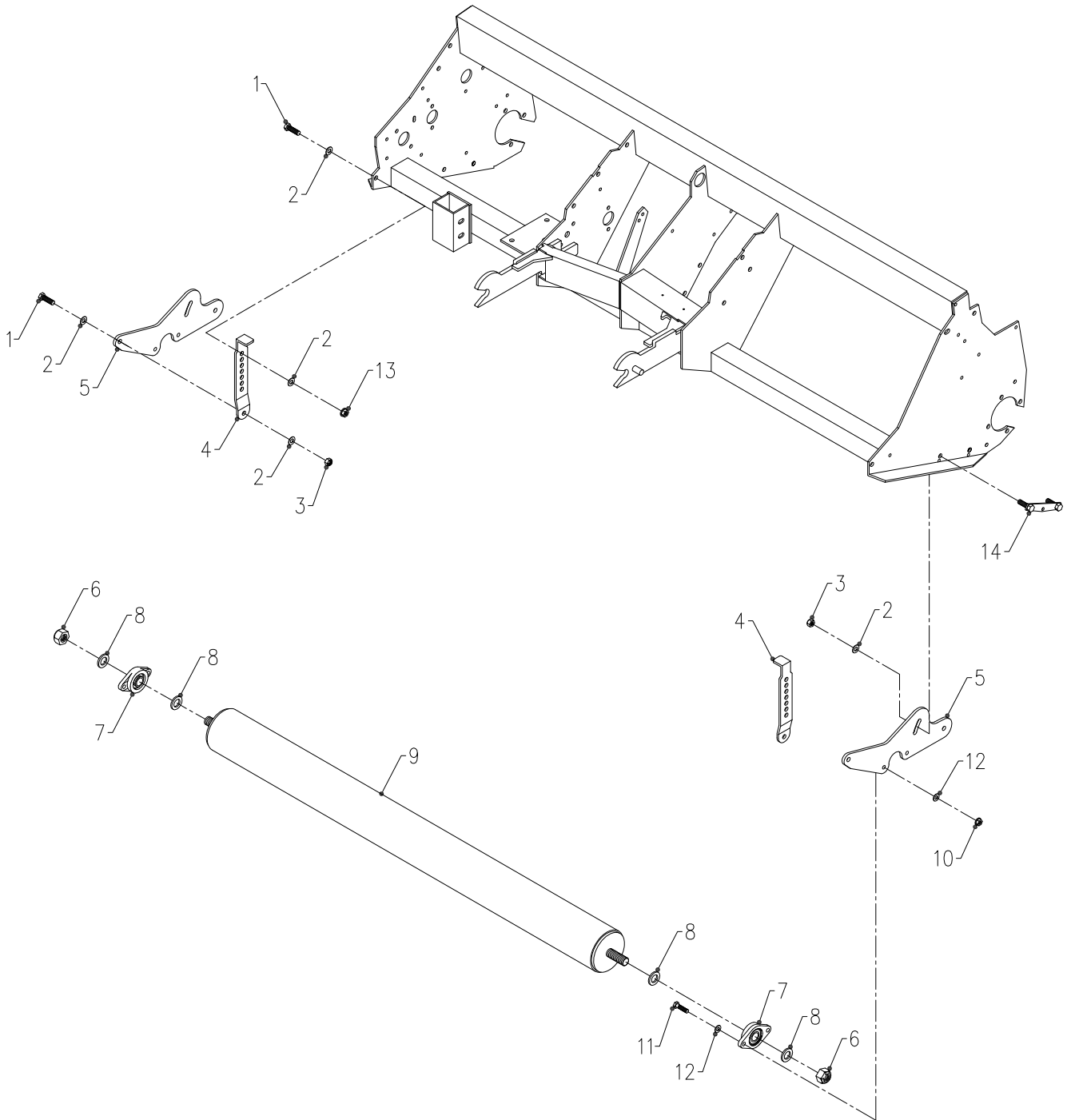

OPTIONS

70.8014 Optional Rear Roller Kit

REF.	PART NO.	DESCRIPTION	QTY.
1	90.0608	.BOLT, 3/8-16 USS X 1	4
2	95.06	.WASHER, FLAT 3/8 SAE	12
3	99.A06	.LOCKNUT, STOVER 3/8-16 USS	6
4	64.1111	.BRACKET, HEIGHT ADJUST	2
5	64.1055	.BRACKET, ROLLER BEARING MT.	2
6	99.A12	.LOCKNUT, STOVER 3/4-10 USS	2
7	55.FB16012-1	.BEARING, FLANGE BLOCK 3/4"	2
8	99.B0057-2	.WASHER, MACH3/4 X1-1/4 10GA ZP	4
9	80.0331	.ROLLER, 4 X 57L	1
10	99.SF05	.NUT, SRF 5/16-18 USS	4
11	90.0510	.BOLT, 5/16-18 USS X 1 1/4	4
12	95.05	.WASHER, FLAT 5/16 SAE	4
13	99.SF06	.NUT, SRF 3/8-16 USS	2
14	64.1056	.BRACKET, BOLT PLATE MT	2

OPTIONS

ILLUSTRATED DRAWING 70.8015 Seeder Kit Mount & Motor

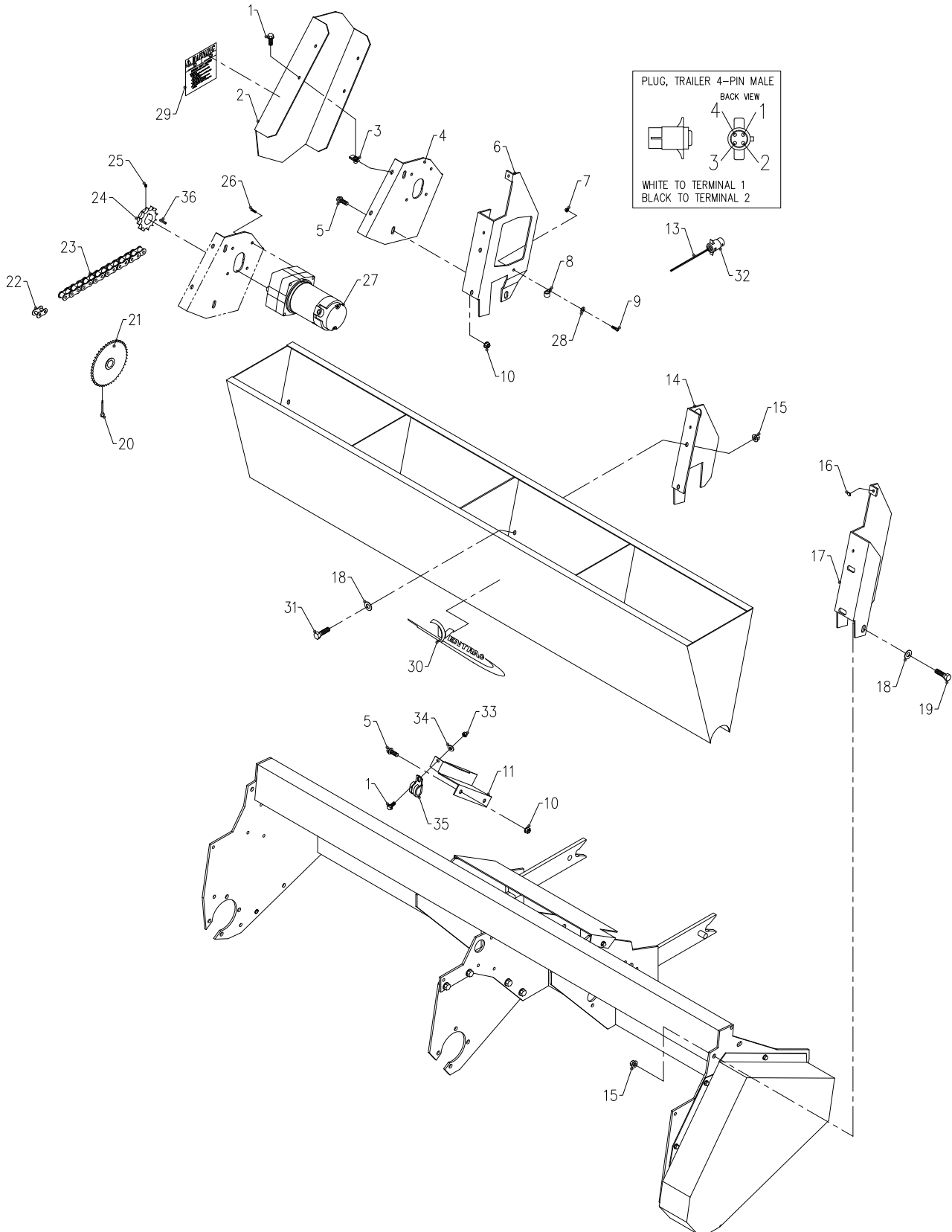

OPTIONS

70.8015 Seeder Kit Mount & Motor

REF.	PART NO.	DESCRIPTION	QTY.
1	99.SF0405-1	.BOLT, SMF 1/4-20 X 5/8	5
2	60.0856	.COVER, DRIVE SEEDER	1
3	99.E0046	.NUT, "U" 1/4-20 EXTRUDED	4
4	62.0961	.MOUNT, SEEDER MOTOR	1
5	99.SF0506	.BOLT, SRF 5/16-18 USS X 3/4	4
6	62.0960	.MOUNT, RIGHT SIDE SEEDER	1
7	99.E0035	.NUT, SRF #10-32	1
8	30.0140	.CLAMP, WIRE MT 3/8 NYLON BLK.	1
9	99.K0071	.MACHINE SCREW, 10-32 X 5/8.	1
10	99.SF05	.NUT, SRF 5/16-18 USS	4
11	64.1057	.BRACKET, WIRE CHANNEL	1
13	32.0075	.HARNES, WIRE SEEDER OPT	1
14	62.0959	.MOUNT, CENTER SEEDER	1
15	99.SF06	.NUT, SRF 3/8-16 USS	8
16	05.0097	.BUMPER, 1/4ID, 9/16OD, 3/16THK	2
17	62.0958	.MOUNT, LEFT SIDE SEEDER	1
18	95.06	.WASHER, FLAT 3/8 SAE	8
19	90.0608	.BOLT, 3/8-16 USS X 1	2
20	02.CP0612	.COTTER PIN, 3/16 X 1 1/2	1
21	07.16118	.SPROCKET, 30-TOOTH 5/8 HEX HUB	1
22	81.0144	.LINK, CONNECTOR #41	1
23	81.0143	.CHAIN, ROLLER #41 X 28-1/2"	1
24	83.411508	.SPROCKET, #41 15-T 1/2" BORE	1
25	85.SS20	.SET SCREW, 10-24 X 3/16	2
26	99.K0073	.BOLT, SHCS 10-32 X 1/2 ZP	4
27	87.0207	.GEARMOTOR, 1/17 HP 30 RPM	1
28	99.B0051	.WASHER, FLAT #10	1
29	00.0626	.DECAL, ENTANGLEMENT HAZARD	1
30	00.0189	.DECAL, VENTRAC ORBITAL (Serial # 1001-4312)	1
30	00.0383	.DECAL, VENTRAC (Serial # 4313-)	1
31	90.0606	.BOLT, 3/8-16 USS X 3/4	6
32	30.0218	.PLUG, TRAILER 4-PIN MALE	1
33	99.A04N	.LOCKNUT, NYLON 1/4-20	1
34	95.04	.WASHER, FLAT 1/4 SAE	1
35	11.0058	.CLAMP, CUSHIONED 3/8"	1
36	85.K0206	.KEY, 1/8 X 3/4	1

OPTIONS

ILLUSTRATED DRAWING 70.8015 Seeder Kit Hopper & Controls

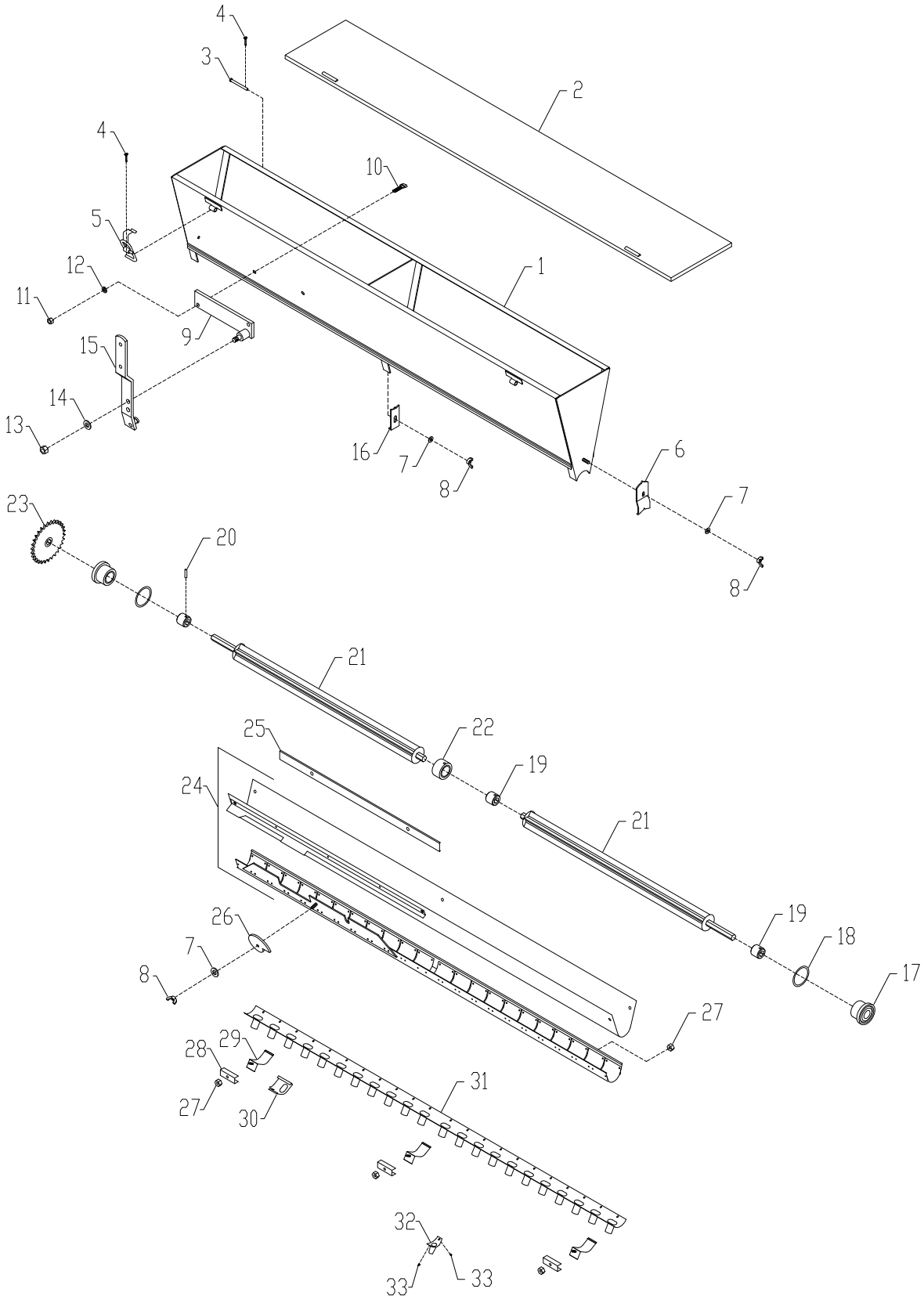

OPTIONS

70.8015 Seeder Kit Hopper & Controls

REF.	PART NO.	DESCRIPTION	QTY.
1	07.16111	.HOPPER, 5-FT., PAINTED BLACK	1
2	07.16112	.COVER, 5-FT., PAINTED BLACK	1
3	03.0421	.CLEVIS PIN, 1/4 X 2-5/8	2
4	02.CP0306	.COTTER PIN, 3/32 X 3/4	4
5	07.16104	.LOCK, COVER	2
6	07.16103	.RETAINER, BEARING	2
7	95.05	.WASHER, FLAT 5/16 SAE	4
8	99.E0003	.NUT, WING 5/16 USS 18	4
9	07.16115	.BRKT, MOUNTING SHUT-OFF LEVER	1
10	90.0608	.BOLT, 3/8-16 USS X 1	2
11	92.06	.NUT, 3/8-16 USS	2
12	96.06	.WASHER, LOCK 3/8	2
13	99.A08	.LOCKNUT, STOVER 1/2-13 USS	1
14	95.08	.WASHER, FLAT 1/2 SAE	1
15	07.16109	.LEVER, SHUT-OFF, PAINTED BLACK	1
16	07.16105	.RETAINER, BEARING - CENTER	1
17	07.16106	.BEARING, END	2
18	07.16120	.GASKET	2
19	07.16108	.JOURNAL, 5/8" HEX	3
20	02.RP0608	.ROLL PIN, 3/16 X 1"	3
21	07.16110	.ROTOR BAR, 5-FT., NEOPRENE	2
22	07.16107	.BEARING, CENTER	1
23	07.16118	.SPROCKET, 30-TOOTH 5/8 HEX HUB	1
24	07.16113	.BOTTOM & SLIDES, 5' 22 OPENING	1
25	07.16101	.HANGER, REAR	2
26	07.16102	.CAM GAUGE	1
27	99.E0098	.NUT, SRF # 10-24	7
28	07.16119	.CLAMP	3
29	07.16117	.HOLDER, CLIP AND PLATE	3
30	07.16116	.CLIP, POSITION	1
31	07.16114	.PLATE, SPOUT MOUNTING W/SPOUTS	1
32	47.0487	.SPOUT, EA SEEDER	22
33	04.0050	.RIVET, SEEDER SPOUT	44