

Parts Manual

MA900

Boom Mower



Revised 01/09/24
09.20032 Rev. 05



500 Venture Drive
Orrville Oh 44667
www.ventrac.com

[View all manuals](#)



Visit ventrac.com/manuals for the latest version of this parts manual.

A downloadable operator's manual is also available.

Serial Number Description

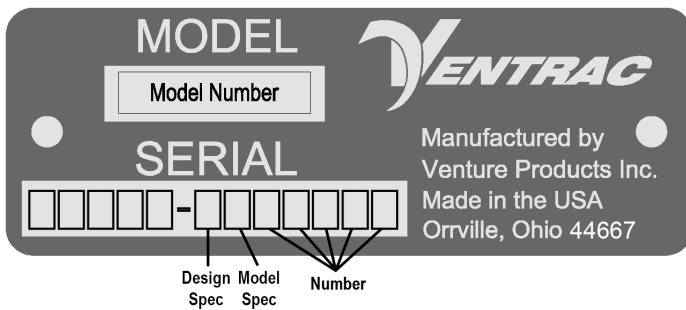

Notes

- If any component requires replacement, use only original Ventrac replacement parts.
- When ordering new components, be sure to order all required safety decals. All current safety decals must be affixed to the replacement components prior to installation of the component.

TABLE OF CONTENTS

PARTS	PAGE 4
Electrical Diagram	4
O-Ring Chart	5
Fitting Chart.....	5
Hydraulic Diagram - Arm & Cutter Bar Rotation.....	8
Hydraulic Diagram - Blade Drive.....	10
Main Frame & Front Rollers	12
Caster Wheels & Jack Stands.....	14
Main Arm Frame, Main Arm Pivots, & Outer Arm Frame	16
Outer Arm Pivots, Top Link Arm, & Eccentric Rocker Pin	18
Cutter Head Pivot, Cutter Bar Frame & Pivot.....	20
Cutter Head Rotation Chains	22
Cutter Head Cover & Cutter Bar Skid Plates	24
Cutter Head Crankshaft	26
Cutter Head Drive Link Rockers.....	28
Cutter Bar Guides	30
Knife Blades, Double Finger Guards, & Cutting Edge Cover.....	32
Hydraulic Pump, Filter, & Relief Valve.....	34
Hydraulic Motor	36
Outer Arm Extension Cylinder.....	38
Boom Control Valve & Indicator Light	40
Boom Control Valve Shields.....	42
Main Arm Rotation Cylinders.....	44
Cutter Bar Rotation Cylinder & Lockout Arm.....	46

PARTS

Electrical Diagram Rear View

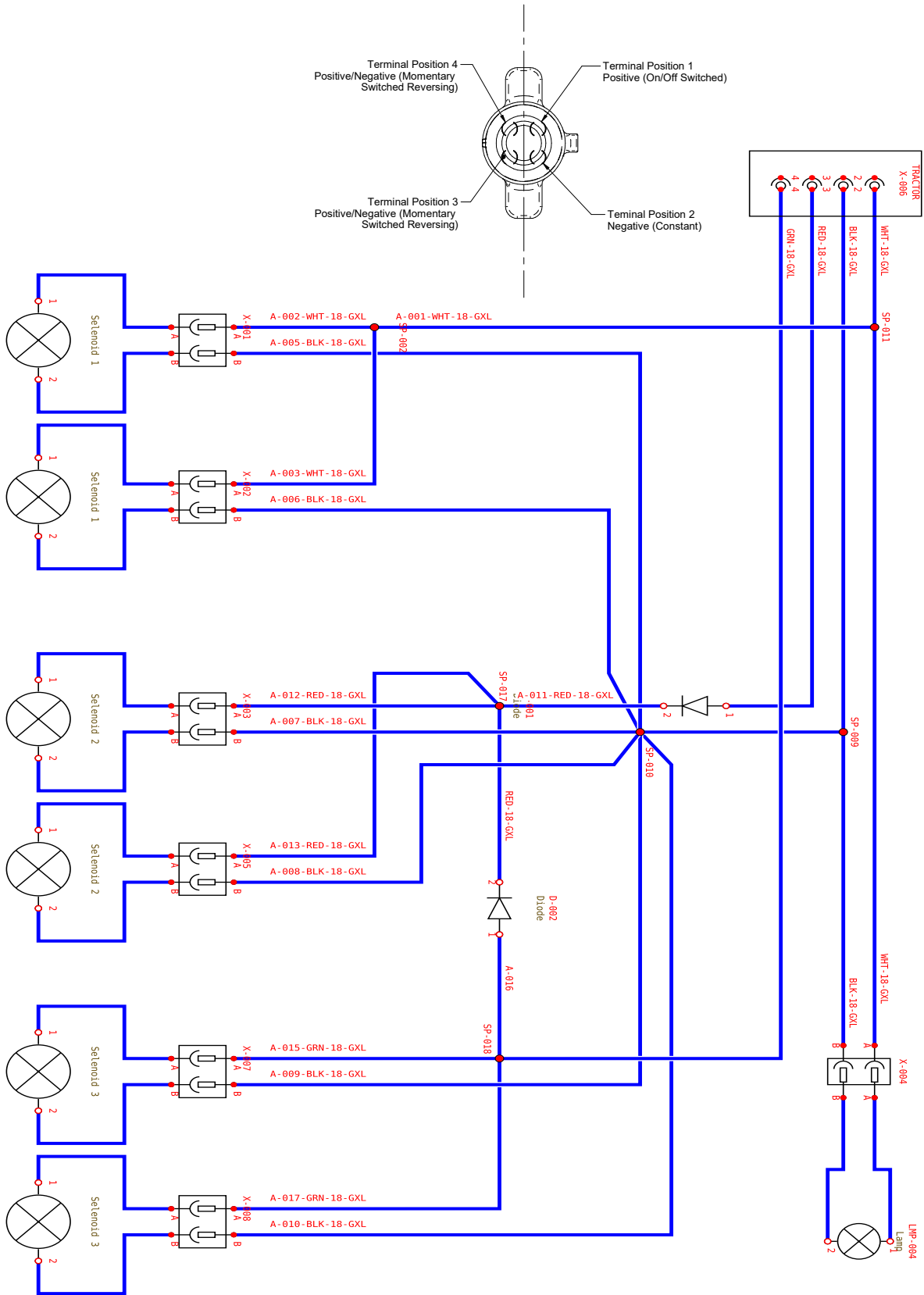

PARTS

O-Ring Chart

Straight Thread O-Ring Boss - O-Ring Replacement Part Numbers						
SAE Fitting Size	Thread Size	VPI Part #	ID	OD	Width	AS568A Dash #
-04	7/16-20	26.0035	0.351"	0.495"	0.072"	904
-06	9/16-18	26.0036	0.468"	0.624"	0.078"	906
-08	3/4-16	26.0037	0.644"	0.818"	0.087"	908
-10	7/8-14	26.0038	0.755"	0.949"	0.097"	910
-12	1-1/16-12	26.0039	0.924"	1.156"	0.116"	912
-16	1-5/16-12	26.0043	1.171"	1.403"	0.116"	916

O-Ring Face Seal Hose - O-Ring Replacement Part Numbers						
SAE Fitting Size	Thread Size	VPI Part #	ID	OD	Width	AS568A Dash #
-04	9/16-18	26.0044	0.301"	0.441"	0.070"	011
-06	11/16-16	26.0025	0.364"	0.504"	0.070"	012
-08	13/16-16	26.0009	0.489"	0.629"	0.070"	014
-10	1-14	26.0023	0.614"	0.754"	0.070"	016
-12	1-3/16-12	26.0045	0.739"	0.879"	0.070"	018
-16	1-7/16-12	26.0046	0.926"	1.066"	0.070"	021

Fitting Chart

25.6408-(xx) Plug

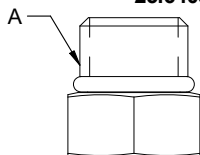

Fitting End A		O-Ring	
SAE Fitting Size	Thread Size	AS568A Dash #	VPI Part #
-04	7/16-20	904	26.0035
-06	9/16-18	906	26.0036
-08	3/4-16	908	26.0037
-10	7/8-14	910	26.0038
-12	1-1/16-12	912	26.0039
-16	1-5/16-12	916	26.0043

25.FF2501-(xx)-(xx) Fitting

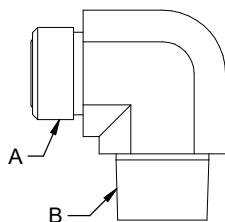

Fitting End A		O-Ring		Fitting End B		O-Ring	
SAE Fitting Size	Thread Size	AS568A Dash #	VPI Part #	SAE Fitting Size	Thread Size	AS568A Dash #	VPI Part #
-04	9/16-18	011	26.0044	-04	1/4-18 NPT	-	-
-06	11/16-16	012	26.0025	-06	3/8-18 NPT	-	-
-08	13/16-16	014	26.0009	-08	1/2-14 NPT	-	-
-10	1-14	016	26.0023	-10	-	-	-
-12	1-3/16-12	018	26.0045	-12	3/4-14 NPT	-	-
-16	1-7/16-12	021	26.0046	-16	1-11 1/2 NPT	-	-

25.FF6400-(xx)-(xx) Fitting

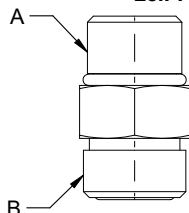

Fitting End A		O-Ring		Fitting End B		O-Ring	
SAE Fitting Size	Thread Size	AS568A Dash #	VPI Part #	SAE Fitting Size	Thread Size	AS568A Dash #	VPI Part #
-04	7/16-20	904	26.0035	-04	9/16-18	011	26.0044
-06	9/16-18	906	26.0036	-06	11/16-16	012	26.0025
-08	3/4-16	908	26.0037	-08	13/16-16	014	26.0009
-10	7/8-14	910	26.0038	-10	1-14	016	26.0023
-12	1-1/16-12	912	26.0039	-12	1-3/16-12	018	26.0045
-16	1-5/16-12	916	26.0043	-16	1-7/16-12	021	26.0046

PARTS

Fitting Chart

25.FF6402-(xx)-(xx) Fitting

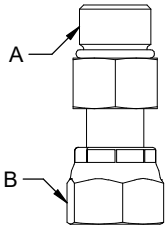

Fitting End A		O-Ring		Fitting End B		O-Ring	
SAE Fitting Size	Thread Size	AS568A Dash #	VPI Part #	SAE Fitting Size	Thread Size	AS568A Dash #	VPI Part #
-04	9/16-18	011	26.0044	-04	9/16-18	-	-
-06	11/16-16	012	26.0025	-06	11/16-16	-	-
-08	13/16-16	014	26.0009	-08	13/16-16	-	-
-10	1-14	016	26.0023	-10	1-14	-	-
-12	1-3/16-12	018	26.0045	-12	1-3/16-12	-	-
-16	1-7/16-12	021	26.0046	-16	1-7/16-12	-	-

25.FF6500-(xx)-(xx) Fitting

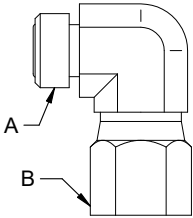

Fitting End A		O-Ring		Fitting End B		O-Ring	
SAE Fitting Size	Thread Size	AS568A Dash #	VPI Part #	SAE Fitting Size	Thread Size	AS568A Dash #	VPI Part #
-04	9/16-18	011	26.0044	-04	9/16-18	-	-
-06	11/16-16	012	26.0025	-06	11/16-16	-	-
-08	13/16-16	014	26.0009	-08	13/16-16	-	-
-10	1-14	016	26.0023	-10	1-14	-	-
-12	1-3/16-12	018	26.0045	-12	1-3/16-12	-	-
-16	1-7/16-12	021	26.0046	-16	1-7/16-12	-	-

25.FF6602-(x)-(x)-(x) Fitting

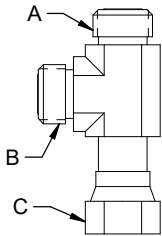

Fitting End A & B		O-Ring		Fitting End C		O-Ring	
SAE Fitting Size	Thread Size	AS568A Dash #	VPI Part #	SAE Fitting Size	Thread Size	AS568A Dash #	VPI Part #
-04	9/16-18	011	26.0044	-04	9/16-18	-	-
-06	11/16-16	012	26.0025	-06	11/16-16	-	-
-08	13/16-16	014	26.0009	-08	13/16-16	-	-
-10	1-14	016	26.0023	-10	1-14	-	-
-12	1-3/16-12	018	26.0045	-12	1-3/16-12	-	-
-16	1-7/16-12	021	26.0046	-16	1-7/16-12	-	-

25.FF6801-(xx)-(xx) Fitting

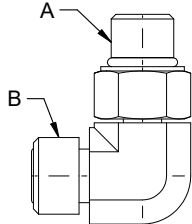

Fitting End A		O-Ring		Fitting End B		O-Ring	
SAE Fitting Size	Thread Size	AS568A Dash #	VPI Part #	SAE Fitting Size	Thread Size	AS568A Dash #	VPI Part #
-04	7/16-20	904	26.0035	-04	9/16-18	011	26.0044
-06	9/16-18	906	26.0036	-06	11/16-16	012	26.0025
-08	3/4-16	908	26.0037	-08	13/16-16	014	26.0009
-10	7/8-14	910	26.0038	-10	1-14	016	26.0023
-12	1-1/16-12	912	26.0039	-12	1-3/16-12	018	26.0045
-16	1-5/16-12	916	26.0043	-16	1-7/16-12	021	26.0046

25.FF6802-(xx)-(xx) Fitting

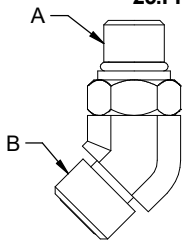

Fitting End A		O-Ring		Fitting End B		O-Ring	
SAE Fitting Size	Thread Size	AS568A Dash #	VPI Part #	SAE Fitting Size	Thread Size	AS568A Dash #	VPI Part #
-04	7/16-20	904	26.0035	-04	9/16-18	011	26.0044
-06	9/16-18	906	26.0036	-06	11/16-16	012	26.0025
-08	3/4-16	908	26.0037	-08	13/16-16	014	26.0009
-10	7/8-14	910	26.0038	-10	1-14	016	26.0023
-12	1-1/16-12	912	26.0039	-12	1-3/16-12	018	26.0045
-16	1-5/16-12	916	26.0043	-16	1-7/16-12	021	26.0046

PARTS

Fitting Chart

25.FF6803-(x)-(x)-(x) Fitting

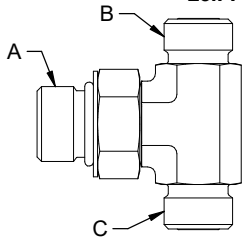

Fitting End A		O-Ring		Fitting End B & C		O-Ring	
SAE Fitting Size	Thread Size	AS568A Dash #	VPI Part #	SAE Fitting Size	Thread Size	AS568A Dash #	VPI Part #
-04	7/16-20	904	26.0035	-04	9/16-18	011	26.0044
-06	9/16-18	906	26.0036	-06	11/16-16	012	26.0025
-08	3/4-16	908	26.0037	-08	13/16-16	014	26.0009
-10	7/8-14	910	26.0038	-10	1-14	016	26.0023
-12	1-1/16-12	912	26.0039	-12	1-3/16-12	018	26.0045
-16	1-5/16-12	916	26.0043	-16	1-7/16-12	021	26.0046

25.FF6804-(x)-(x)-(x) Fitting

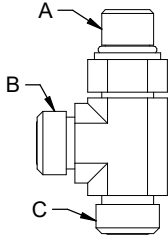

Fitting End A		O-Ring		Fitting End B & C		O-Ring	
SAE Fitting Size	Thread Size	AS568A Dash #	VPI Part #	SAE Fitting Size	Thread Size	AS568A Dash #	VPI Part #
-04	7/16-20	904	26.0035	-04	9/16-18	011	26.0044
-06	9/16-18	906	26.0036	-06	11/16-16	012	26.0025
-08	3/4-16	908	26.0037	-08	13/16-16	014	26.0009
-10	7/8-14	910	26.0038	-10	1-14	016	26.0023
-12	1-1/16-12	912	26.0039	-12	1-3/16-12	018	26.0045
-16	1-5/16-12	916	26.0043	-16	1-7/16-12	021	26.0046

PARTS

ILLUSTRATED DRAWING Hydraulic Diagram - Arm & Cutter Bar Rotation

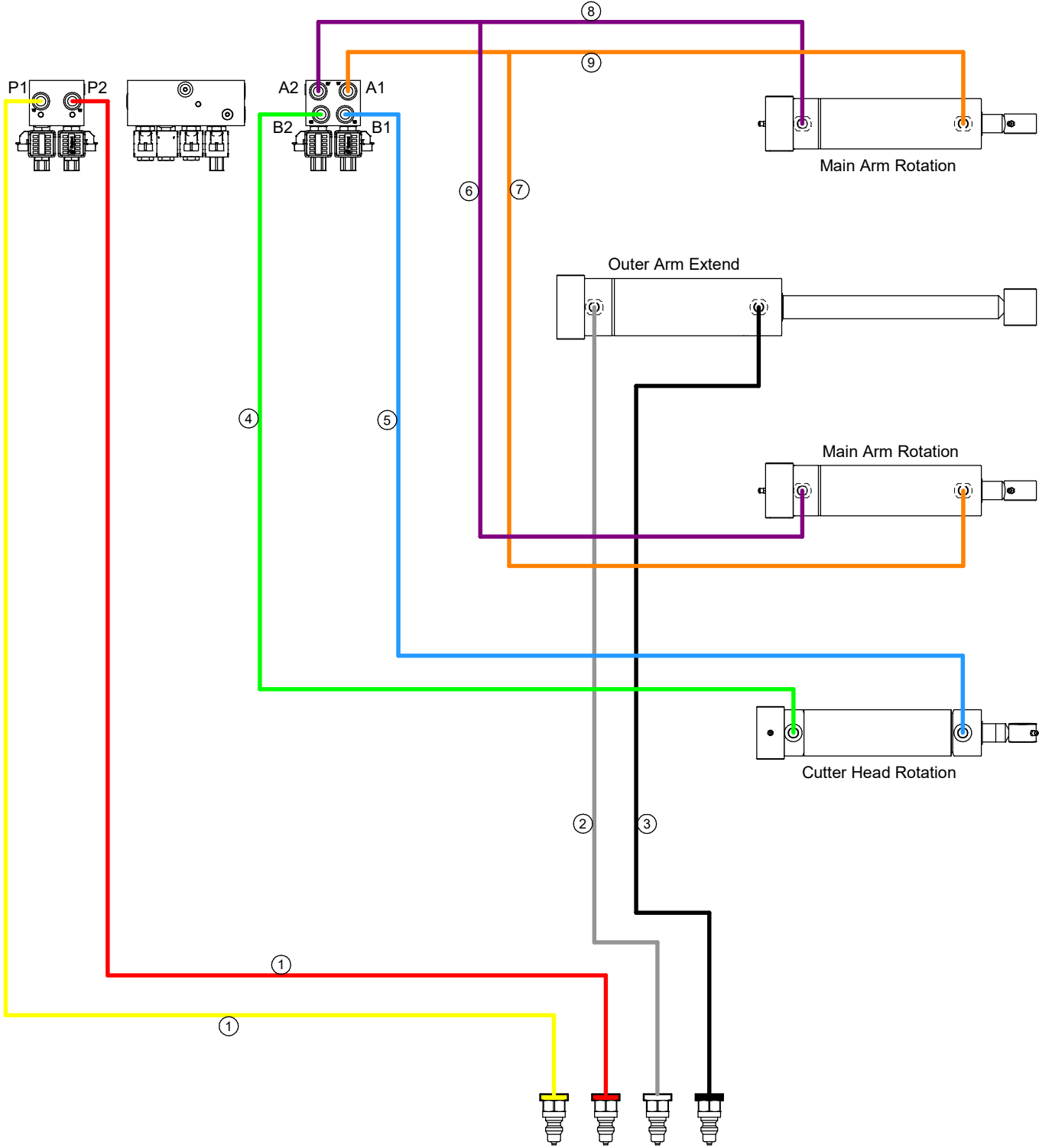

PARTS

Hydraulic Diagram - Arm & Cutter Bar Rotation

REF.	PART NO.	DESCRIPTION	QTY.
1	20.0348	.Hose, 1/4x72.00 SAE 100R17AR.	2
2	20.0349	.Hose, 1/4x132.00 SAE 100R17AR.	1
3	20.0350	.Hose, 1/4x136.00 SAE 100R17AR.	1
4	20.0353	.Hose, 1/4x27.00 SAE 100R17AR.	1
5	20.0354	.Hose, 1/4x37.00 SAE 100R17AR.	1
6	20.0356	.Hose, 1/4x14.00 SAE 100R17AR.	1
7	20.0355	.Hose, 1/4x23.00 SAE 100R17AR.	1
8	20.0351	.Hose, 1/4x20.00 SAE 100R17AR.	1
9	20.0352	.Hose, 1/4x15.00 SAE 100R17AR.	1

PARTS

ILLUSTRATED DRAWING Hydraulic Diagram - Blade Drive

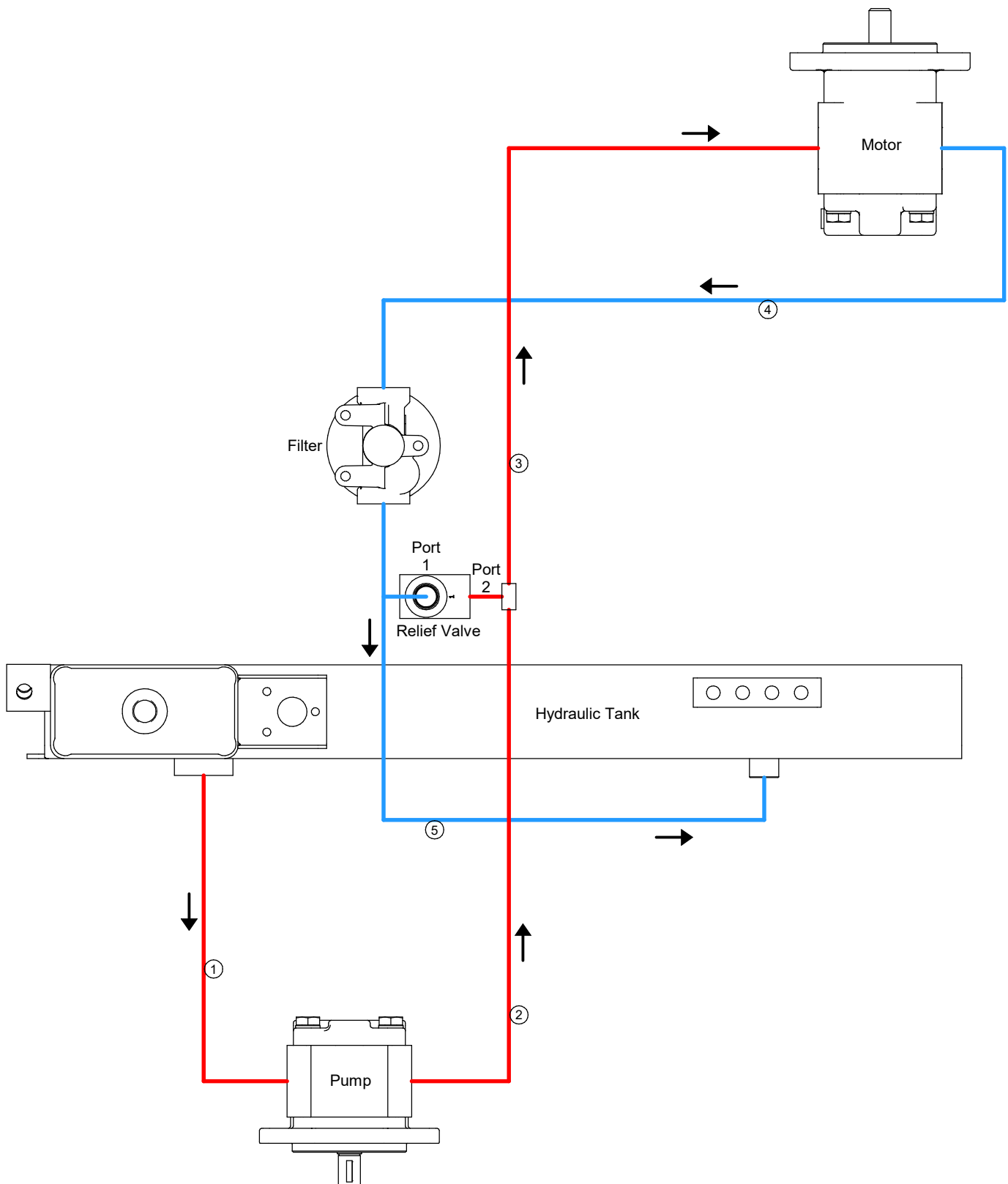

PARTS

Hydraulic Diagram - Blade Drive

REF.	PART NO.	DESCRIPTION	QTY.
1	20.0360	Hose, 3/4x19.00 SAE 100R4 EX FLEX	1
2	20.0361	Hose, 3/8x16.00 SAE 100R17AR	1
3	20.0357	Hose, 3/8x180.00 SAE 100R19AR	1
4	20.0358	Hose, 1/2x177.00 SAE 100R19AR	1
5	20.0359	Hose, 1/2x36.00 SAE 100R17AR	1

PARTS

ILLUSTRATED DRAWING Main Frame & Front Rollers

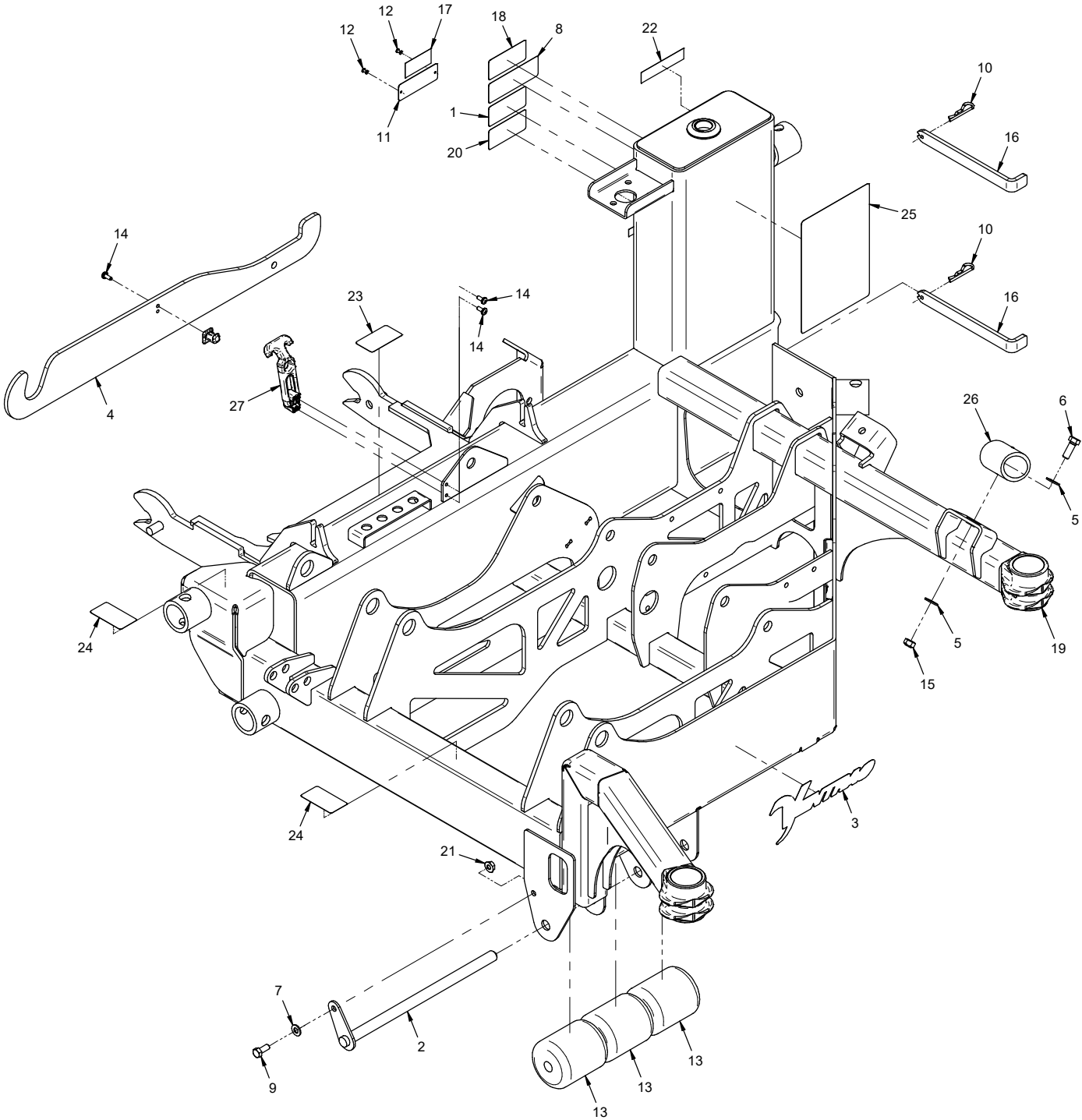

PARTS

Main Frame & Front Rollers

REF.	PART NO.	DESCRIPTION	QTY.
1	00.0217	.Decal, Warning Read Owners Man (Serial # 01001-02000)	1
1	00.0619	.Decal, Read Operator's Manual (Serial # 02001-)	1
2	MA-6027	.Pin, Roller Retainer	1
3	00.0383	.Decal, Ventrac	1
4	MA-1438	.Link, Lockout	1
5	95.06	.Washer, Flat 3/8 SAE	2
6	90.0608	.Bolt, 3/8-16 USS x 1	1
7	95.05	.Washer, Flat 5/16 SAE	1
8	00.0102	.Decal, Danger - Pinching Hazard (Serial # 01001-02000)	1
8	00.0620	.Decal, Pinching or Crushing Hazard (Serial # 02001-)	1
9	90.0506	.Bolt, 5/16-18 USS x 3/4	1
10	02.HP0416	.Hairpin, 1/8 X 2	2
11	N/A	.Plate, Ventrac Serial Number	1
12	04.0029	.Rivet, Pop 1/8" X 1/4" SS	2
13	50.0047	.Roller, Front 3" Dia X 3-1/2"	3
14	99.K0072	.Machine Screw, 10-24 X 1/2 ZP	3
15	99.A06	.Locknut, Stover 3/8-16 USS	1
16	MA-1380	.Pin, Weight Keeper	2
17	00.0100	.Decal, Built In the USA	1
18	00.0103	.Decal, Hazard - High Press. Fluid (Serial # 01001-02000)	1
18	00.0621	.Decal, High Pressure Fluid Hazard (Serial # 02001-)	1
19	MA-6000	.Frame, Main MA900	1
20	00.0220	.Decal, General Safety (Serial # 01001-02000)	1
20	00.0632	.Decal, Moving Parts Hazard (Serial # 02001-)	1
21	99.SF05	.Nut, SRF 5/16-18 USS	1
22	00.0148	.Decal, Hyd. Oil 3-7/16 x 3/4	1
23	00.0216	.Decal, Warning Moving Parts (Serial # 01001-02000)	1
23	00.0631	.Decal, Finger /Hand Entanglement (Serial # 02001-)	1
24	00.0218	.Decal, Warning Pinch Point (Serial # 01001-02000)	2
24	00.0364	.Decal, Warning Pinch Point (Serial # 02001-)	2
25	00.0495	.Decal, Maintenance MA	1
26	05.0137	.Bumper, Elastomer 475 Lbs PF	1
27	47.0127	.Latch, Rubber Draw T-Handle	1

PARTS

ILLUSTRATED DRAWING Caster Wheels & Jack Stands

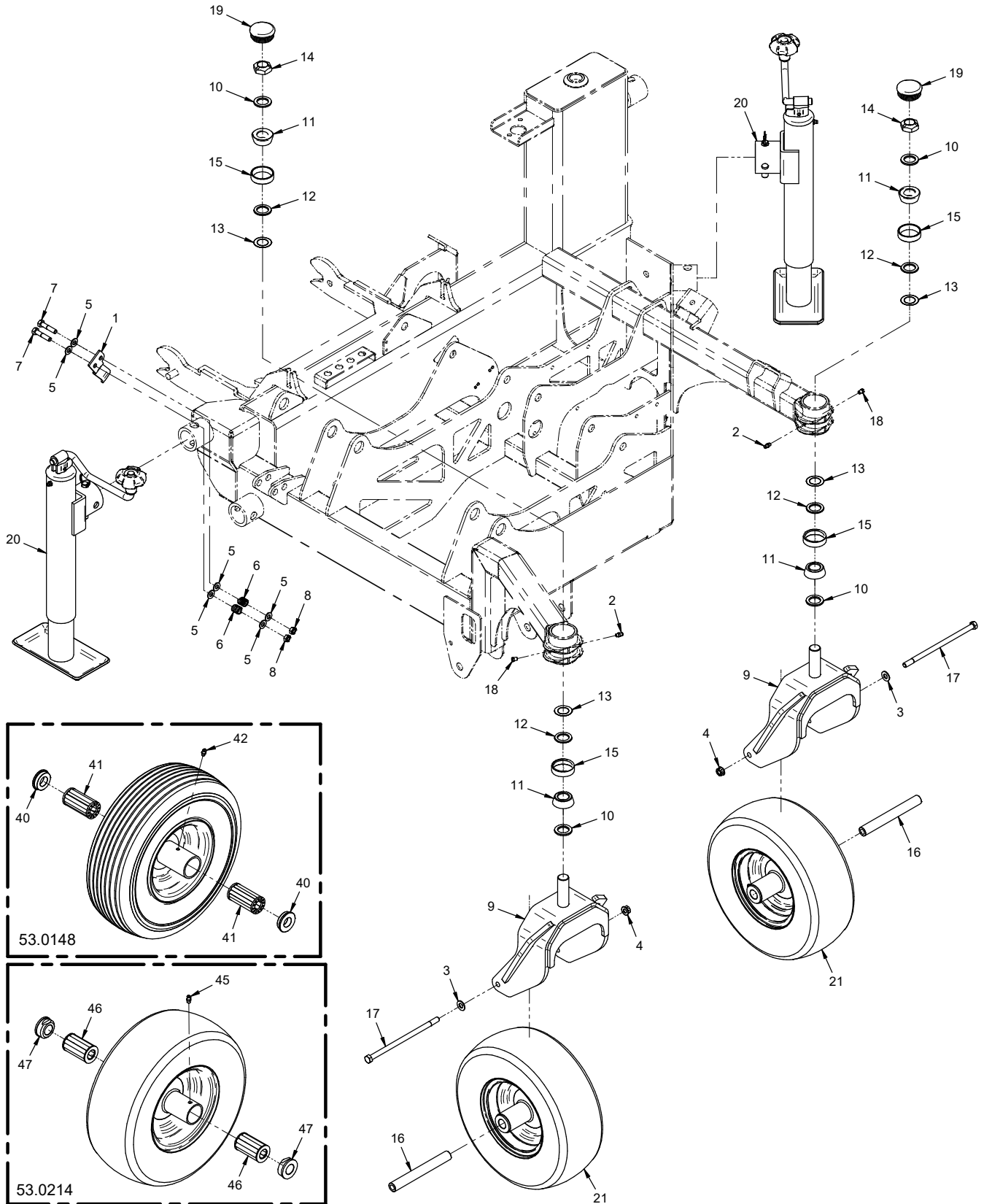

PARTS

Caster Wheels & Jack Stands

REF.	PART NO.	DESCRIPTION	QTY.
1	MA-1501	.Latch, Jack Handle	1
2	29.GF0001	.Grease Ftg, 1/4 SAE ST	2
3	95.06	.Washer, Flat 3/8 SAE	2
4	99.E0082	.Nut, Locking Flange 3/8-16	2
5	95.05	.Washer, Flat 5/16 SAE	6
6	41.0039	.Spring, Comp. 9/16 OD X 5/8	2
7	90.0512	.Bolt, 5/16-18 USS x 1-1/2	2
8	99.A05	.Locknut, Stover 5/16-18 USS	2
9	MA-6037	.Yoke, Caster 13" Heavy	2
10	99.B0119	.Washer, Mach 7/8 x 1-3/8 x 10 GA	4
11	55.LM12749LA2	.Bearing, Taper Roller Cone	4
12	85.B0099	.Bushing, .875ID x 1.375OD x .120T	4
13	85.B0101	.Bushing, .005 Spacer	4
14	99.M0047	.Locknut, Stover M22 X 1.5 ZP	2
15	55.LM12710	.Bearing, Cup	4
16	50.0050	.Tube, Swivel Axle	2
17	90.0660	.Bolt, 3/8-16 USS x 7-1/2	2
18	29.GF0011	.Grease Ftg, Plug 1/4-28	2
19	05.0172	.Plug, Ribbed Black LDPE	2
20	47.0428	.Jack, Trailer Swivel Topwind	2
21	53.0148	.Wheel, Asm 13x5x6 Rib Flatfree (Serial # 01001-01782)	2
21	53.0214	.Wheel, Asm 13x5x6 Rib Flatfree (Serial # 01783-)	2
40	55.0072	.Bearing, Retainer 3/4"	2
41	55.0088	.Bearing, Roller Replacement	2
42	29.GF0001	.Grease Ftg, 1/4 SAE ST	1
45	29.GF0001	.Grease Ftg, 1/4 SAE ST	1
46	55.0116	.Bearing, Roller 2.25" Long	2
47	55.0114	.Retainer, Roller Bearing 3/4"	2

PARTS

ILLUSTRATED DRAWING Main Arm Frame, Main Arm Pivots, & Outer Arm Frame

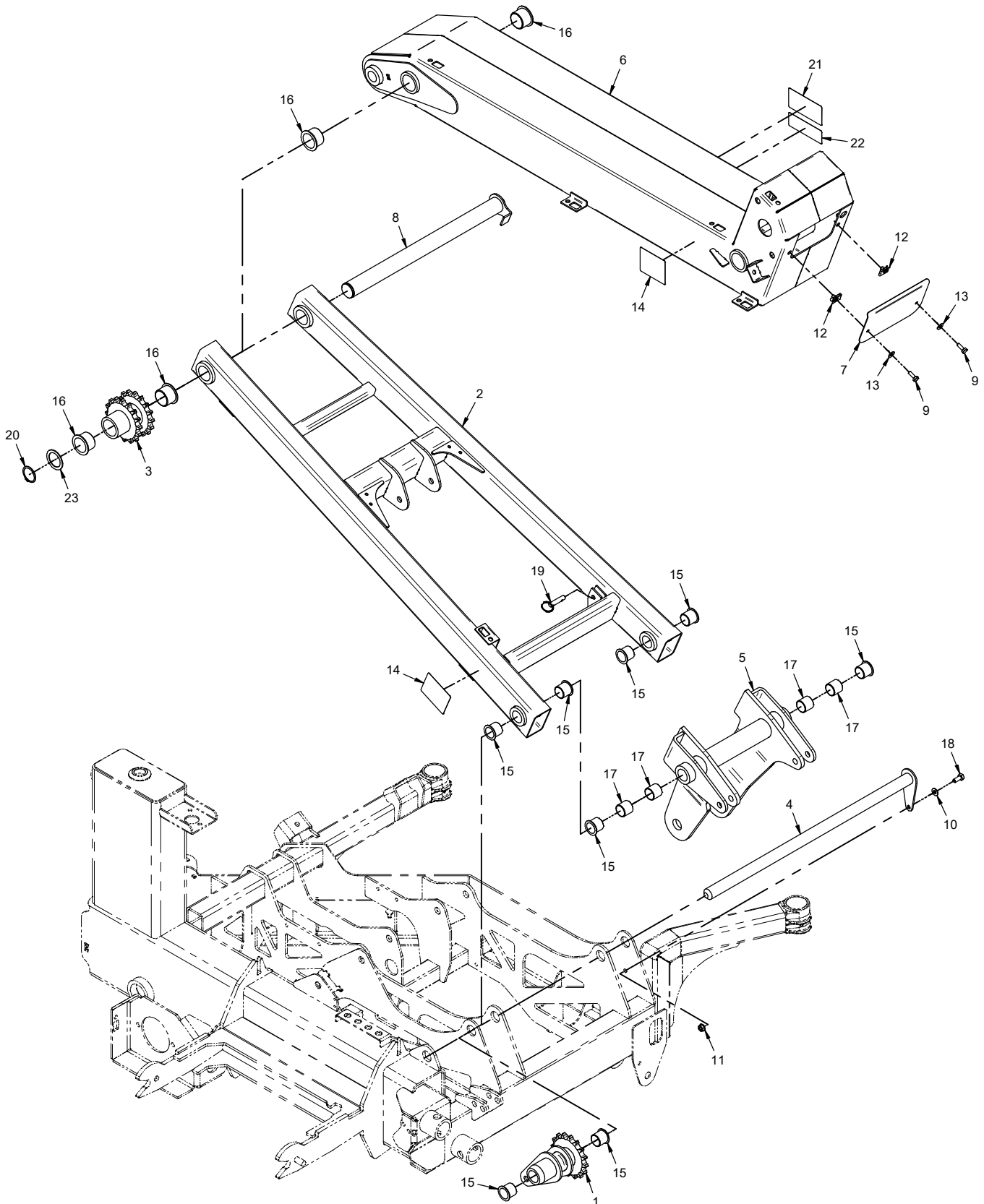

PARTS

Main Arm Frame, Main Arm Pivots, & Outer Arm Frame

REF.	PART NO.	DESCRIPTION	QTY.
1	MA-6026	Sprocket, Base Rocker	1
2	MA-6004	Frame, Main Arm	1
3	MA-6015	Sprocket, Double Inner	1
4	MA-6001	Pin, Main Pivot	1
5	MA-6002	Rocker, Main Pivot	1
6	MA-6005	Frame, Outer Arm	1
7	MA-1419	Cover, Cutter Head Pivot	1
8	MA-6006	Pin, Boom Pivot	1
9	90.0406	Bolt, 1/4-20 USS x 3/4	2
10	95.05	Washer, Flat 5/16 SAE	1
11	99.SF05	Nut, SRF 5/16-18 USS	1
12	99.E0046	Nut, "U" 1/4-20 Extruded	2
13	95.04	Washer, Flat 1/4 SAE	2
14	00.0492	Decal, Shield Missing (Serial # 01001-02000)	2
14	00.0625	Decal, Shield Missing (Serial # 02001-)	2
15	85.B0102	Bushing, 1.000 ID x 1.125 OD x 1 L	8
16	85.B0103	Bushing, 1.375 ID x 1.531 OD x 1 L	4
17	85.B0104	Bushing, 1.000 ID x 1.125 OD x 1 L	4
18	90.0506	Bolt, 5/16-18 USS x 3/4"	1
19	03.0006	Pin, Ball 3/8 X 1"	1
20	04.0043	Snap Ring, Ext. 1-3/8" Shaft .05 W	1
21	00.0494	Decal, Keep Clear MA900 (Serial # 01001-02000)	1
21	00.0641	Decal, Overhead Arm Hazard (Serial # 02001-)	1
22	00.0493	Decal, Frame Pinch Point (Serial # 01001-02000)	1
22	00.0620	Decal, Pinching or Crushing Hazard (Serial # 02001-)	1
23	99.B0135	Shim, 1-3/8 ID x 1-7/8 OD x .06 SS	1

PARTS

ILLUSTRATED DRAWING

Outer Arm Pivots, Top Link Arm, & Eccentric Rocker Pin

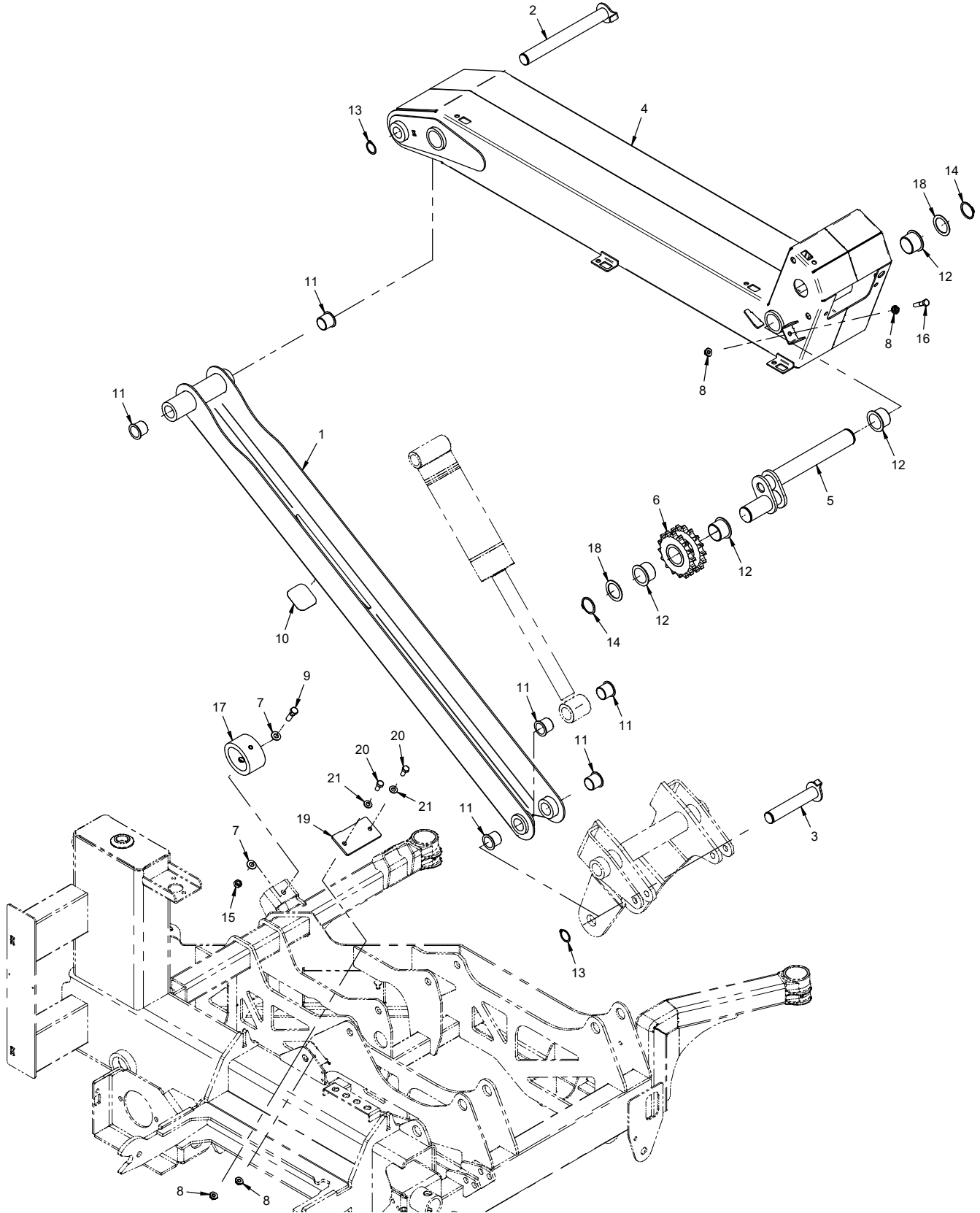

PARTS

Outer Arm Pivots, Top Link Arm, & Eccentric Rocker Pin

REF.	PART NO.	DESCRIPTION	QTY.
1	MA-6007	.Frame, top link	1
2	MA-6009	.Pin, Boom Pivot Upper	1
3	MA-6008	.Pin, Linkage Pivot Lower	1
4	MA-6005	.Frame, Outer Arm	1
5	MA-6013	.Rocker, Eccentric Pin	1
6	MA-6014	.Sprocket, Double Outer	1
7	95.06	.Washer, Flat 3/8 SAE	2
8	99.SF05	.Nut, SRF 5/16-18 USS	4
9	90.0610	.Bolt, 3/8-16 USS x 1-1/4	1
10	00.0501	.Decal, Wear Resistant	1
11	85.B0102	.Bushing, 1.000 ID x 1.125 OD x 1 L	6
12	85.B0103	.Bushing, 1.375 ID x 1.531 OD x 1 L	4
13	04.0016	.Snap Ring, Ext.1 Shft .042 Thk	2
14	04.0043	.Snap Ring, Ext. 1-3/8" Shaft .05 W	2
15	99.A06	.Locknut, Stover 3/8-16 USS	1
16	90.0512	.Bolt, 5/16-18 USS x 1-1/2	1
17	05.0169	.Bumper, Elastomer 1300 Lbs PF	1
18	99.B0135	.Shim, 1-3/8 ID x 1-7/8 OD x .06 SS	as required
19	MA-1147	.Plate, Pivot Stop (Serial # 01461 -)	1
20	90.0506	.Bolt, 5/16-18 USS x 3/4 (Serial # 01461 -)	2
21	95.05	.Washer, Flat 5/16 SAE (Serial # 01461 -)	2

PARTS

ILLUSTRATED DRAWING Cutter Head Pivot, Cutter Bar Frame & Pivot

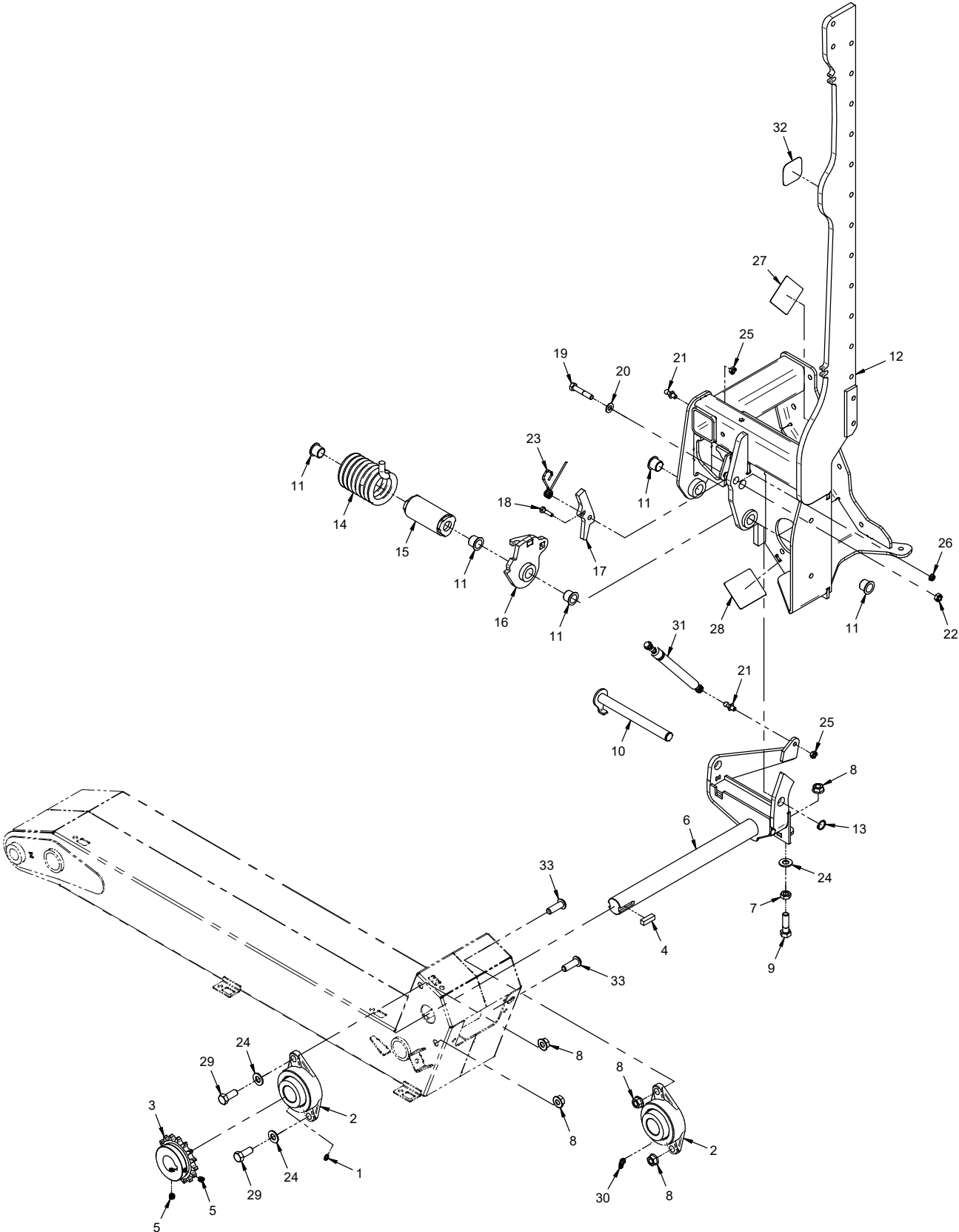

PARTS

Cutter Head Pivot, Cutter Bar Frame & Pivot

REF.	PART NO.	DESCRIPTION	QTY.
1	29.GF0001	.Grease Ftg, 1/4 SAE ST	1
2	55.FB16023	.Bearing, Flange Block 1-7/16"	2
3	83.601623	.Sprocket, #60 16-T 1-7/16" Bore	1
4	85.K0610	.Key, 3/8 X 1-1/4	1
5	85.SS21	.Set Screw, 3/8-16 x 3/8	2
6	MA-6010	.Mount, Cutter Head	1
7	99.E0058	.Nut, Jam 1/2-13 USS	1
8	99.SF08	.Nut, SRF 1/2-13 USS	5
9	90.0814	.Bolt, 1/2-13 USS x 1-3/4	1
10	MA-6023	.Pin, Head Pivot	1
11	85.B0105	.Bushing, .750 ID x .875 OD x .689 L	5
12	MA-6016	.Frame, Cutter Bar	1
13	04.0045	.Snap Ring, Ext. 3/4" Shaft .042 W	1
14	41.0121	.Spring, Torsion MA900	1
15	MA-6019	.Bushing, Spring Drum	1
16	MA-6020	.Retainer, Spring Latch	1
17	MA-1406	.Latch, Spring	1
18	90.0408	.Bolt, 1/4-20 USS x 1	1
19	90.0616	.Bolt, 3/8-16 USS x 2	1
20	95.06	.Washer, Flat 3/8 SAE	1
21	47.0225	.Stud, Ball 10mm 5/16-18 Thread	2
22	99.A06	.Locknut, Stover 3/8-16 USS	1
23	41.0124	.Spring, Torsion 0.41 X 3-1/4	1
24	95.08	.Washer, Flat 1/2 SAE	3
25	99.A05	.Locknut, Stover 5/16-18 USS	2
26	99.SF04	.Nut, SRF 1/4-20 USS	1
27	00.0123	.Decal, Keep Hands & Feet Clear (Serial # 01001-02000)	1
27	00.0624	.Decal, Cutting Hazard Hands and Feet (Serial # 02001-)	1
28	00.0492	.Decal, Shield Missing (Serial # 01001-02000)	1
28	00.0625	.Decal, Shield Missing (Serial # 02001-)	1
29	90.0810	.Bolt, 1/2-13 USS x 1-1/4	2
30	29.GF0002	.Grease Ftg, 1/4 SAE 90	1
31	47.0440	.Damper, Hydraulic 12.795"	1
32	00.0501	.Decal, Wear Resistant	1
33	99.0812	.Bolt, 1/2-13 x 1-1/2 BSCS	2

PARTS

ILLUSTRATED DRAWING Cutter Head Rotation Chains

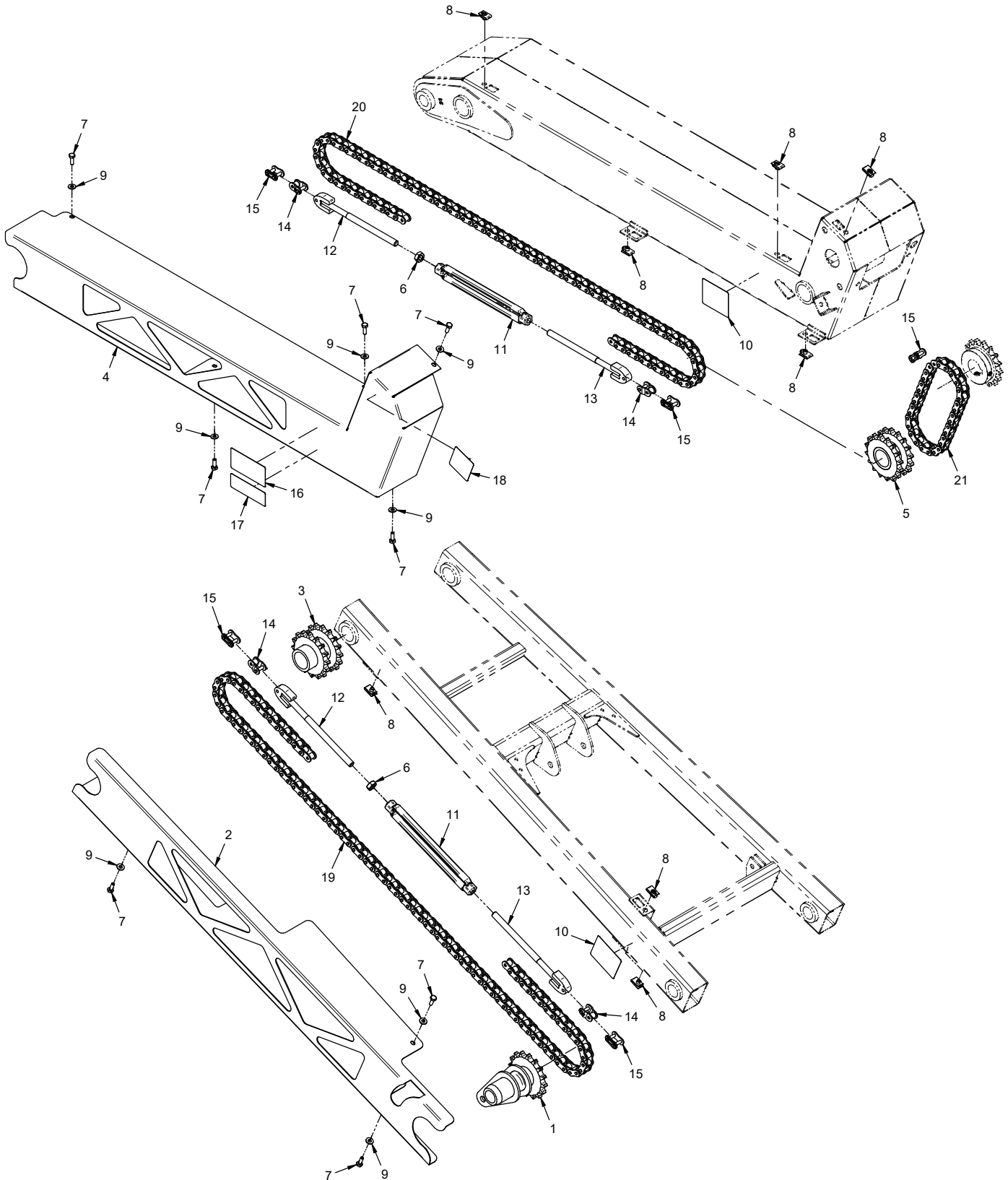

PARTS

Cutter Head Rotation Chains

REF.	PART NO.	DESCRIPTION	QTY.
1	MA-6026	.Sprocket, Base Rocker	1
2	MA-1402	.Guard, Chain Main Arm	1
3	MA-6015	.Sprocket, Double Inner	1
4	MA-1401	.Guard, Chain Outer Arm	1
5	MA-6014	.Sprocket, Double Outer	1
6	99.E0058	.Nut, Jam 1/2-13 USS	2
7	90.0406	.Bolt, 1/4-20 USS x 3/4	8
8	99.E0046	.Nut, "U" 1/4-20 Extruded	8
9	95.04	.Washer, Flat 1/4 SAE	8
10	00.0492	.Decal, Shield Missing (Serial # 01001-02000)	2
10	00.0625	.Decal, Shield Missing (Serial # 02001-)	2
11	47.0441	.Turnbuckle, 1/2-13 x 10.875	2
12	MA-6032	.1/2-13 Turnbuckle RH	2
13	MA-6033	.1/2-13 Turnbuckle LH	2
14	81.0077	.Link, Half #60	4
15	81.0024	.Link, Connector #60	5
16	00.0494	.Decal, Keep Clear MA900 (Serial # 01001-02000)	1
16	00.0641	.Decal, Overhead Arm Hazard (Serial # 02001-)	1
17	00.0493	.Decal, Frame Pinch Point (Serial # 01001-02000)	1
17	00.0620	.Decal, Pinching or Crushing Hazard (Serial # 02001-)	1
18	00.0496	.Decal, Do Not Submerge (Serial # 01001-02000)	1
18	00.0651	.Decal, Do Not Submerge (Serial # 02001-)	1
19	81.0175	.Chain, Roller #60 x 71-1/4"	1
20	81.0176	.Chain, Roller #60 x 68-1/4"	1
21	81.0177	.Chain, Roller #60 x 23-1/4"	1

PARTS

ILLUSTRATED DRAWING Cutter Head Cover & Cutter Bar Skid Plates

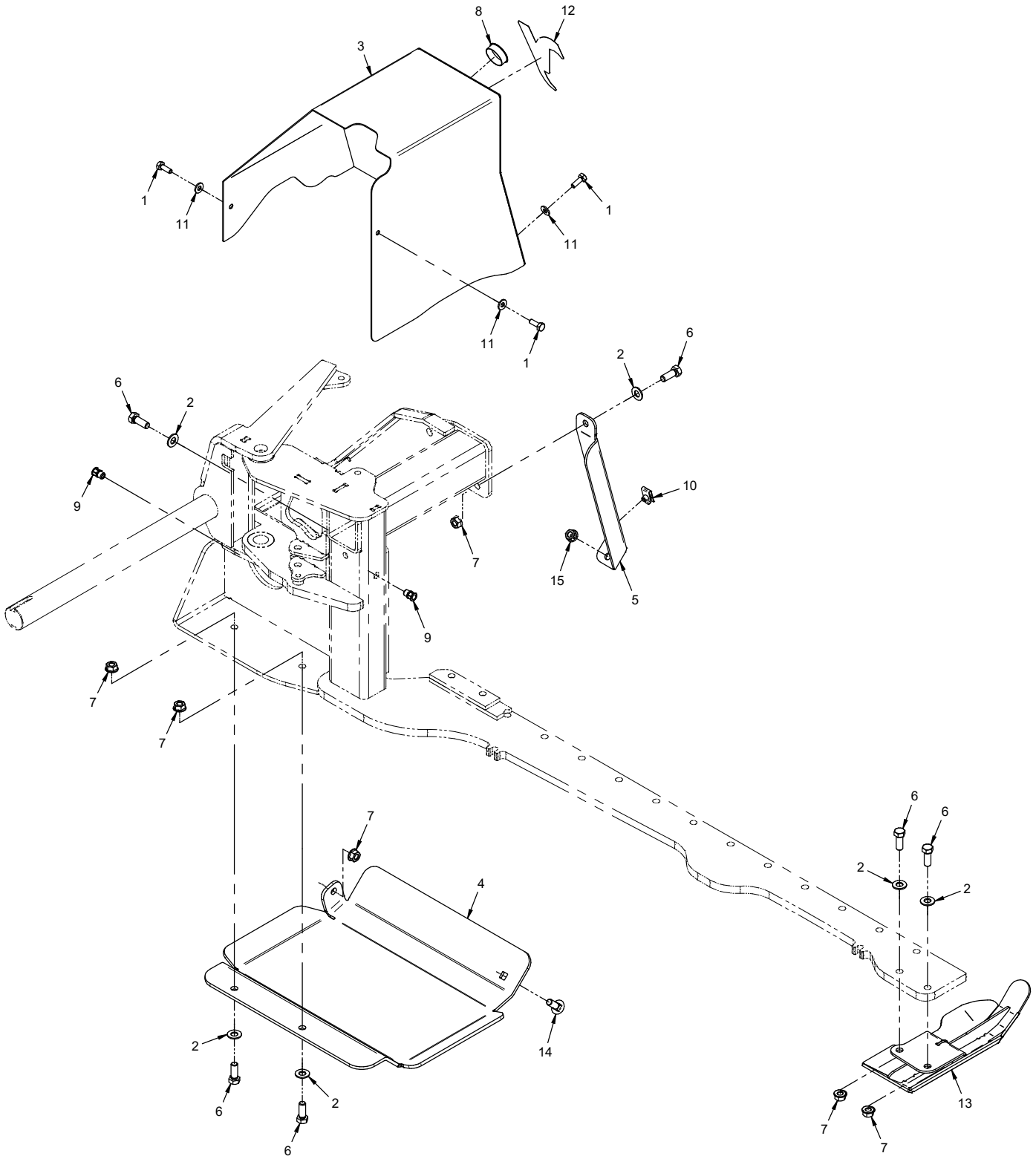

PARTS

Cutter Head Cover & Cutter Bar Skid Plates

REF.	PART NO.	DESCRIPTION	QTY.
1	90.0406	.Bolt, 1/4-20 USS x 3/4	3
2	95.06	.Washer, Flat 3/8 SAE	6
3	MA-6028	.Cover, Cutter Drive	1
4	MA-1473	.Plate, Skid	1
5	MA-1474	.Bracket, Skid Plate Support	1
6	90.0608	.Bolt, 3/8-16 USS x 1	6
7	99.SF06	.Nut, SRF 3/8-16 USS	6
8	05.0091	.Plug, 1-1/4" Hole, Blk Plastic	1
9	99.E0105	.Nut, Insert 1/4-20 Hex	2
10	99.E0046	.Nut, "U" 1/4-20 Extruded	1
11	95.04	.Washer, Flat 1/4 SAE	3
12	00.0192	.Decal, V-Decal Die Cut Blue	1
13	MA-6030	.Shoe, Skid	1
14	97.0608	.Bolt, Carriage 3/8-16 x 1	1
15	99.E0082	.Nut, Locking Flange 3/8-16	1

PARTS

ILLUSTRATED DRAWING Cutter Head Crankshaft

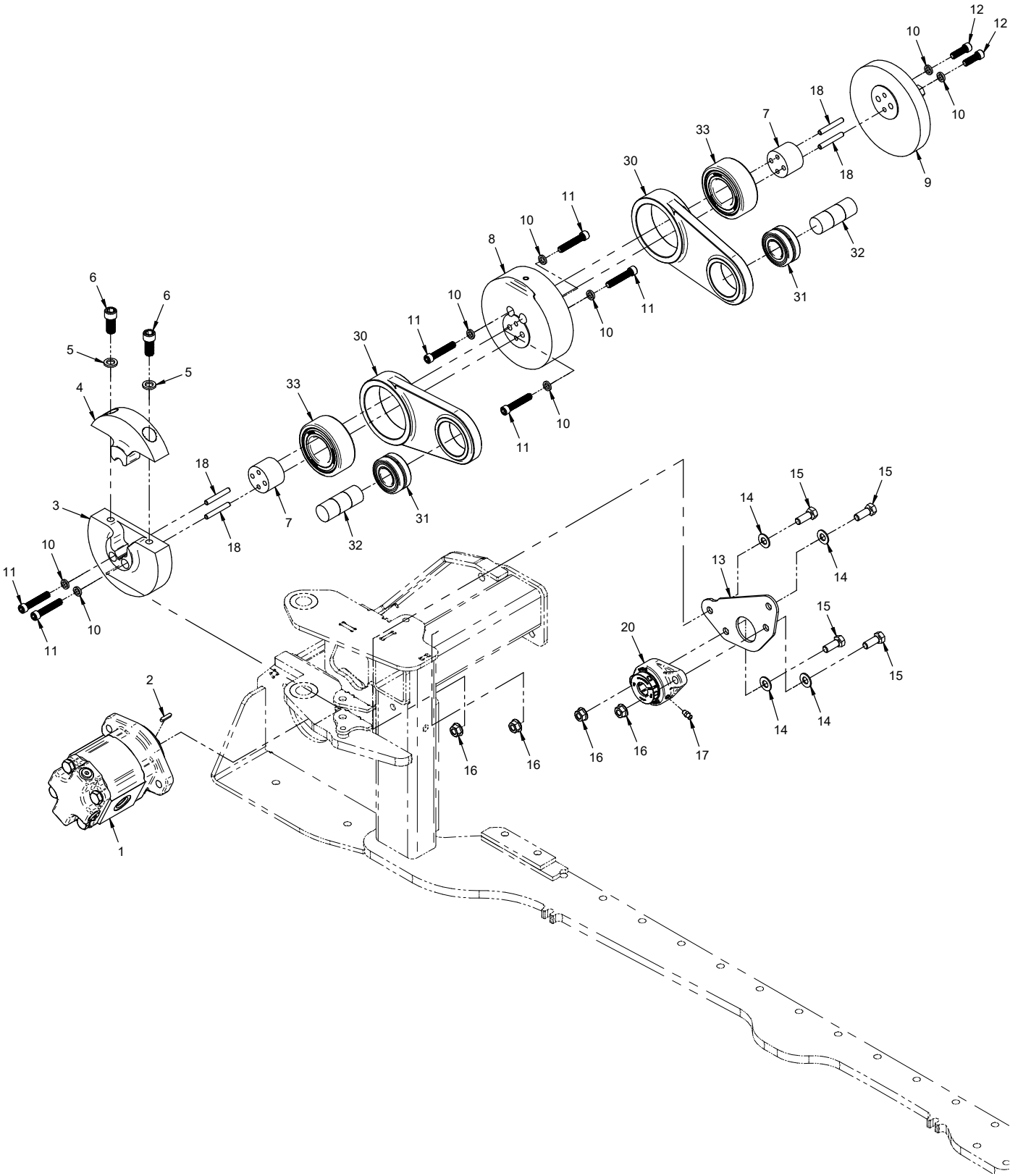

PARTS

Cutter Head Crankshaft

REF.	PART NO.	DESCRIPTION	QTY.
1	21.0136	.Motor, HYD Parker 16cc	1
2	85.K419A	.Key, 4MM x 19 Form A	1
3	MA-1351	.Crankshaft, Drive Plate	1
4	MA-1388	.Clamp, Crankshaft Drive Plate	1
5	96.07-2	.Washer, Nordlock 7/16"	2
6	99.K0158	.Bolt, SHCS 7/16-20 x 1 Grd 8	2
7	MA-1399	.Pin, Crankshaft Drive	2
8	MA-1350	.Crankshaft, Mid Plate	1
9	MA-1349	.Crankshaft, End Plate	1
10	96.05-2	.Washer, Nordlock 5/16"	8
11	99.K0157	.Bolt, SHCS 5/16-24 x 1-3/4 Grd 8	6
12	99.K0155	.Bolt, SHCS 5/16-24 x 1 Grd 8	2
13	MA-1293	.Plate, Bearing Mount	1
14	95.06	.Washer, Flat 3/8 SAE	4
15	90.0608	.Bolt, 3/8-16 USS x 1	4
16	99.SF06	.Nut, SRF 3/8-16 USS	4
17	29.GF0001	.Grease Ftg, 1/4 SAE ST	1
18	03.0031	.Pin, Dowel 1/4 x 1-3/4	4
20	55.FB16012-3	.Bearing, Flange Block 3/4" Grip-It	1
30	MA-1314	.Rod, Crankshaft	2
31	55.0105	.Bearing, Roller 25mm x 52mm x 23mm	2
32	MA-1394	.Shaft, Drive Link Pin	2
33	55.0104	.Bearing, Ball 40MM x 80MM x 30MM	2

PARTS

ILLUSTRATED DRAWING Cutter Head Drive Link Rockers

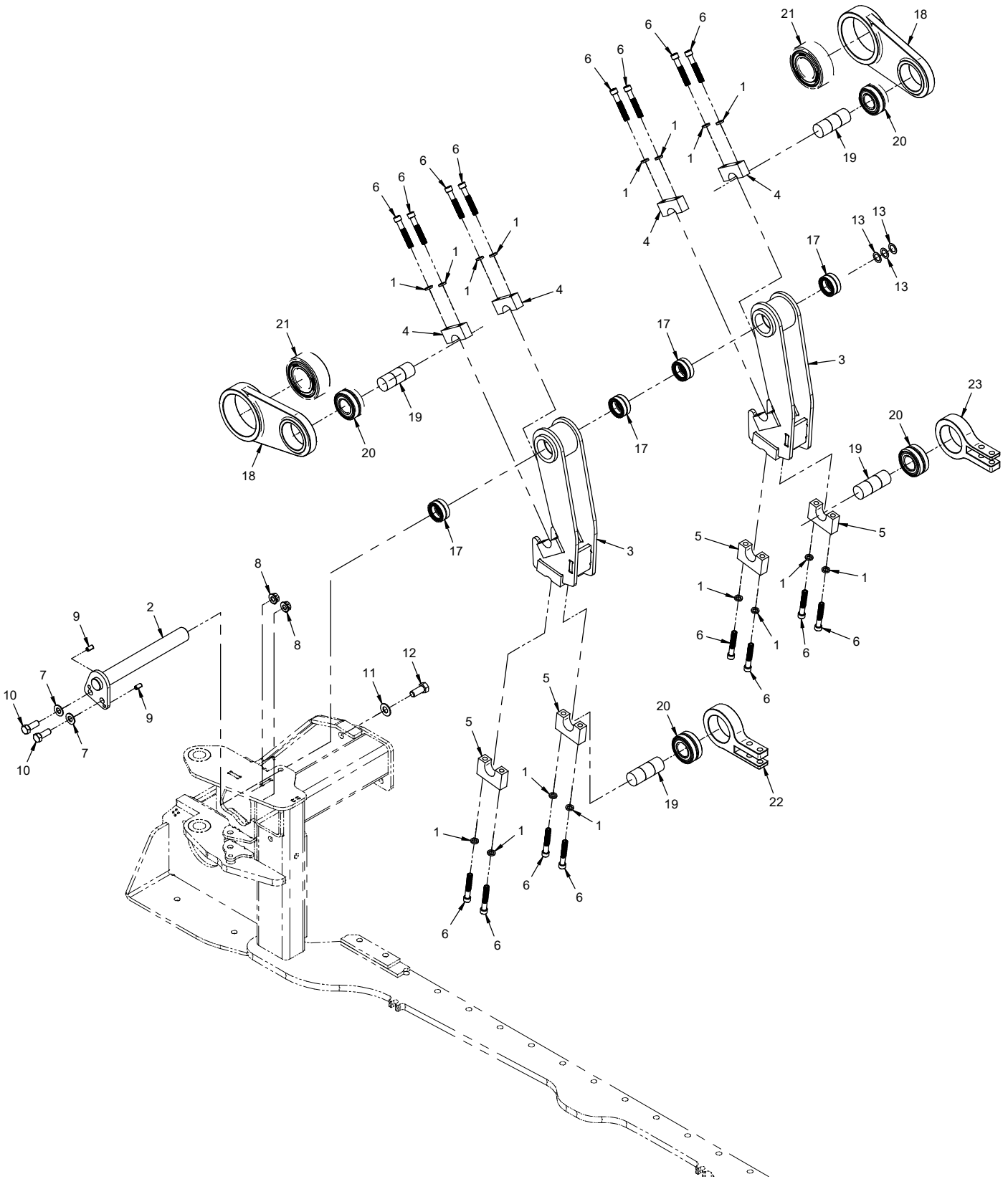

PARTS

Cutter Head Drive Link Rockers

REF.	PART NO.	DESCRIPTION	QTY.
1	96.05-2	.Washer, Nordlock 5/16"	16
2	MA-6025	.Pin, Top Pivot	1
3	MA-6024	.Rocker, Drive Link	2
4	MA-1392	.Clamp, Drive Cap	4
5	MA-1455	.Clamp, Cutter Cap	4
6	99.K0159	.Bolt, SHCS 5/16-24 x 2 Grade 8	16
7	95.06	.Washer, Flat 3/8 SAE	2
8	99.E0082	.Nut, Locking Flange 3/8-16	2
9	02.RP0804	.Roll Pin, 1/4 x 1/2	2
10	90.0608	.Bolt, 3/8-16 USS x 1	2
11	95.07	.Washer, Flat 7/16 SAE	1
12	90.0708	.Bolt, 7/16-14 USS x 1	1
13	99.B0136	.Shim, 1/2 ID x 3/4 OD x .02" T	as required
17	55.0106	.Bearing, Needle 25MM X 37MM X 17MM	4
18	MA-1314	.Rod, Crankshaft	2
19	MA-1394	.Shaft, Drive Link Pin	4
20	55.0105	.Bearing, Roller 25mm x 52mm x 23mm	4
21	55.0104	.Bearing, Ball 40MM x 80MM x 30MM	2
22	MA-1461	.Housing, Bearing Guard	1
23	MA-1457	.Housing, Bearing Blade	1

PARTS

ILLUSTRATED DRAWING Cutter Bar Guides

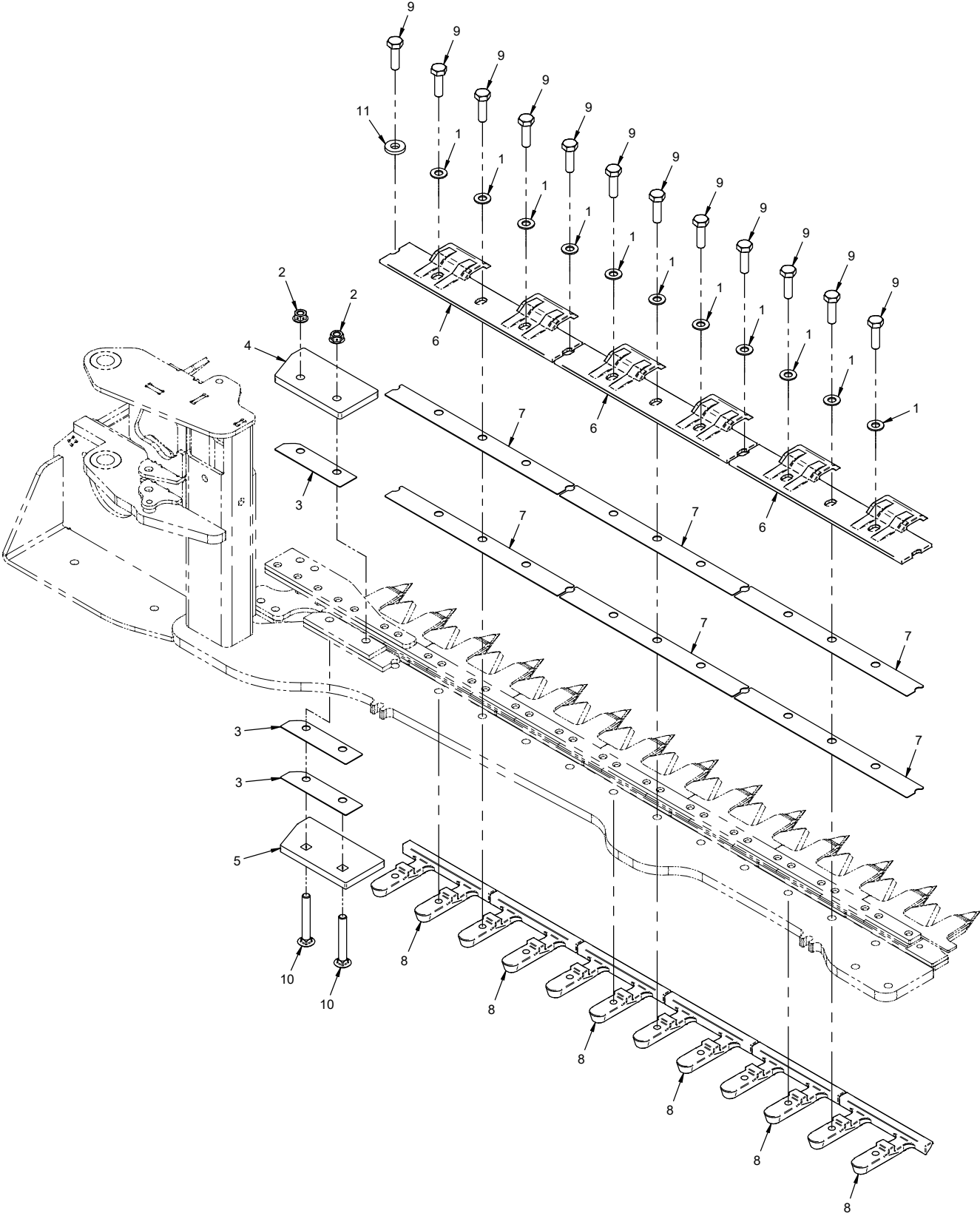

PARTS

Cutter Bar Guides

REF.	PART NO.	DESCRIPTION	QTY.
1	95.06	Washer, Flat 3/8 SAE	11
2	99.E0082	Nut, Locking Flange 3/8-16	2
3	MA-1479	Plate, Shim 20 GA SS	3
4	MA-1482	Clamp, Blade Drive Top	1
5	MA-1484	Clamp, Blade Drive Bottom	1
6	42.0588	Guide, Upper	3
7	MA-1429	Shim, Upper Guide	6
8	42.0589	Guide, Double Inner	6
9	99.M0017	Bolt, M10 X 1.5 X 35 MM	12
10	97.0622	Bolt, Carriage 3/8-16 x 2-3/4	2
11	99.G0014	Washer, 3/8 USS FW .165 Thk.	1

PARTS

ILLUSTRATED DRAWING

Knife Blades, Double Finger Guards, & Cutting Edge Cover

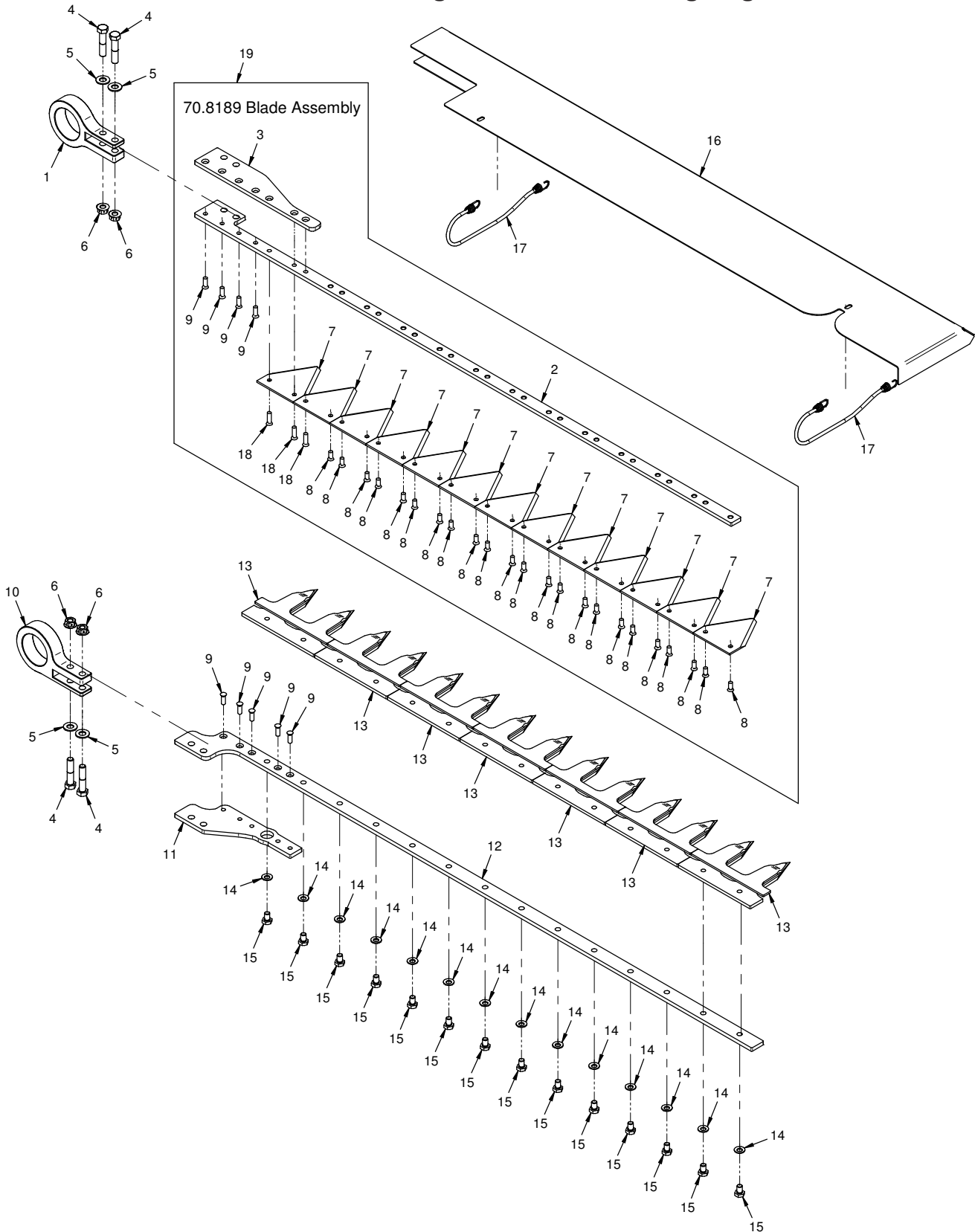

PARTS

Knife Blades, Double Finger Guards, & Cutting Edge Cover

REF.	PART NO.	DESCRIPTION	QTY.
1	MA-1457	.Housing, Bearing Blade	1
2	MA-1458	.Plate, Blade Mount	1
3	MA-1460	.Plate, Blade Drive	1
4	90.0614	.Bolt, 3/8-16 USS x 1-3/4	4
5	95.06	.Washer, Flat 3/8 SAE	4
6	99.E0082	.Nut, Locking Flange 3/8-16	4
7	79.0112	.Blade, Single Knife	13
8	04.0041	.Rivet, 6MM x 13MM Long	23
9	04.0046	.Rivet, 6MM x 16MM Long	9
10	MA-1461	.Housing, Bearing Guard	1
11	MA-1462	.Plate, Guard Drive	1
12	MA-1459	.Plate, Guard Mount	1
13	47.0412	.Guard, Double Finger	7
14	99.M0057	.Washer, French Lock M8	14
15	99.M0056	.Bolt, M8 x 1.0 x 12MM 10.9	14
16	MA-6029	.Cover, Cutting Edge	1
17	47.0425	.Bungee, Bellows Support	2
18	04.0042	.Rivet, 6MM x 19MM Long	3
19	70.8189	.Kit, Blade Asm. MA900	1

PARTS

ILLUSTRATED DRAWING Hydraulic Pump, Filter, & Relief Valve

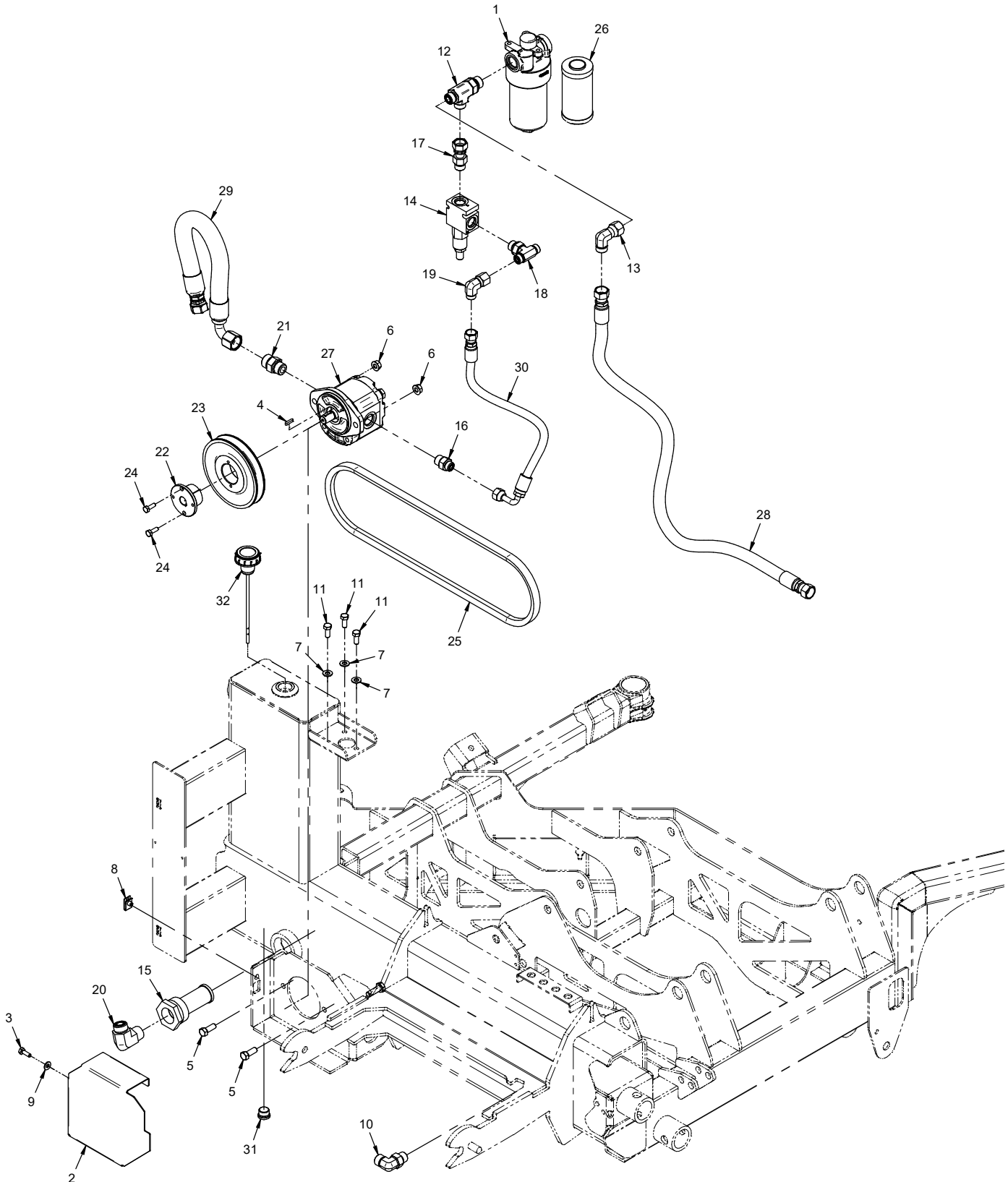

PARTS

Hydraulic Pump, Filter, & Relief Valve

REF.	PART NO.	DESCRIPTION	QTY.
1	21.0137	.Filter, HYD ASM 25 Micron	1
2	MA-1492	.Cover, Belt Guard	1
3	90.0406	.Bolt, 1/4-20 USS x 3/4	1
4	85.K419A	.Key, 4MM x 19 Form A	1
5	90.0608	.Bolt, 3/8-16 USS x 1	2
6	99.SF06	.Nut, SRF 3/8-16 USS	2
7	95.05	.Washer, Flat 5/16 SAE	3
8	99.E0046	.Nut, "U" 1/4-20 Extruded	1
9	95.04	.Washer, Flat 1/4 SAE	1
10	25.FF6801-08-08	.Fitting, 90 Elbow 8MB x 8MFF	1
11	99.M0005	.Bolt, M8 X 1.25 P X 20MM Long	3
12	25.FF6804-8-10-8	.Fitting, M Tee 08MFF x 10MB x 08MFF	1
13	25.FF6500-08-08	.Fitting, 90 Elbow 8MFF x 8FSX	1
14	23.0185	.Valve, Relief 3600 PSI	1
15	21.0143	.Strainer, Hyd. 100 Mesh	1
16	25.FF6400-06-08	.Fitting, Connector 06MFF x 08MB	1
17	25.FF6402-08-08	.Fitting, Connector 08MB x 08FFF	1
18	25.FF6803-6-6-8	.Fitting, M Tee 06MFF x 06MFF x 08MB	1
19	25.FF6500-06-06	.Fitting, 90 Elbow 6MFF x 6FFS	1
20	25.FF2501-10-12	.Fitting, 90 ME 10MFF x 12MP	1
21	25.FF6400-10-10	.Fitting, Connector 10MFF x 10MB	1
22	83.H10	.Bushing, 5/8" H	1
23	83.BK55H	.Pulley, 5.5" H-Bushing	1
24	90.0406	.Bolt, 1/4-20 USS x 3/4	2
25	81.B049	.Belt, B49	1
26	21.0138	.Filter, Hyd Element 25 Micron	1
27	21.0135	.Pump, Hyd. Parker 4CC 5/8" Shaft	1
27	89.0116	.Seal Kit, Pump	1
28	20.0359	.Hose, 1/2x36.00 SAE 100R17AR	1
29	20.0360	.Hose, 3/4x19.00 SAE 100R4 EX Flex	1
30	20.0361	.Hose, 3/8x16.00 SAE 100R17AR	1
31	25.6408-H-08	.Fitting, -08 MB x Hollow Allen	1
32	23.0127	.Dipstick, Asm 6-3/4"	1

PARTS

ILLUSTRATED DRAWING Hydraulic Motor

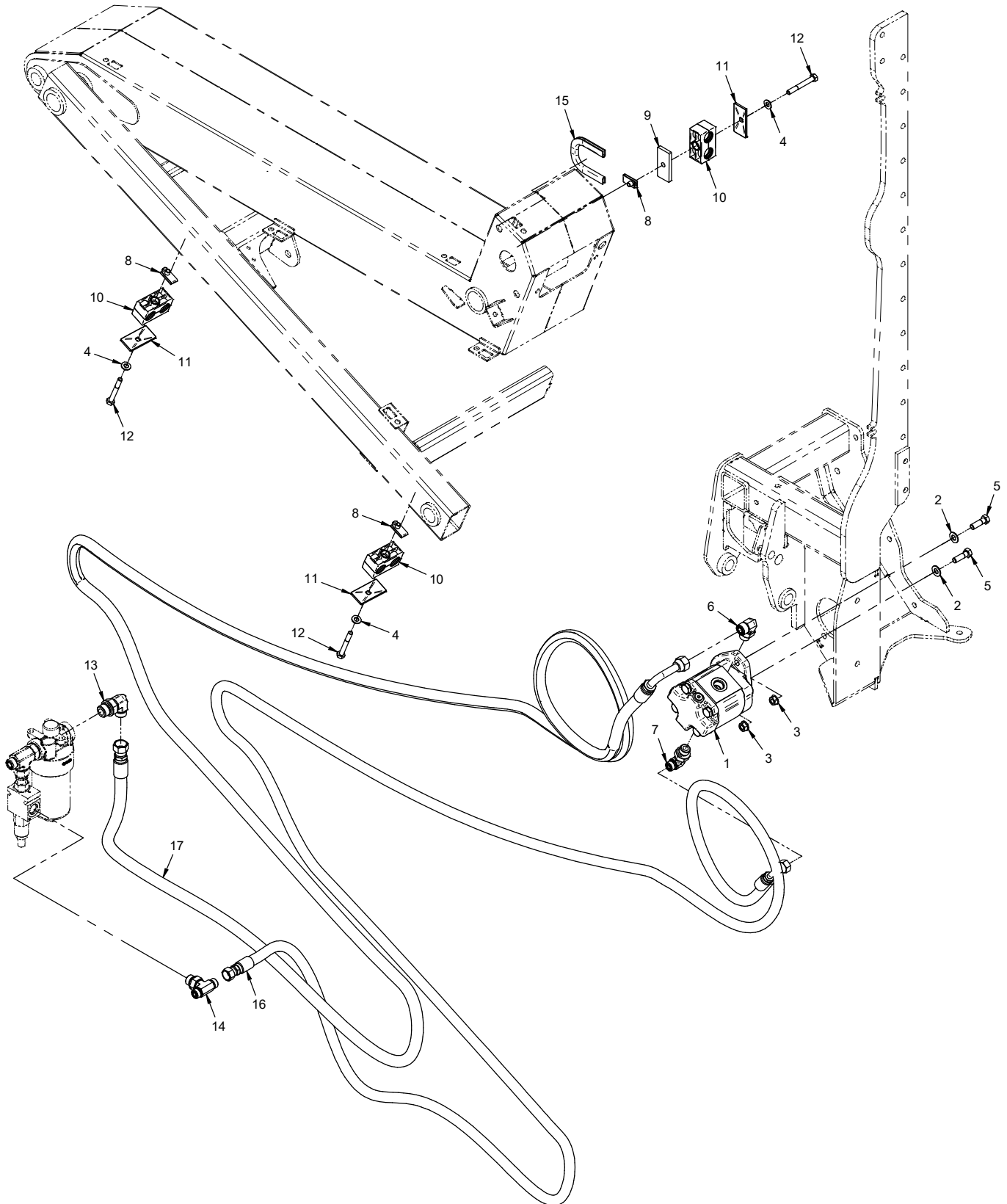

PARTS

Hydraulic Motor

REF.	PART NO.	DESCRIPTION	QTY.
1	21.0136	.Motor, HYD Parker 16cc	1
2	95.06	.Washer, Flat 3/8 SAE	2
3	99.SF06	.Nut, SRF 3/8-16 USS	2
4	95.05	.Washer, Flat 5/16 SAE	3
5	90.0610	.Bolt, 3/8-16 USS x 1-1/4	2
6	25.FF6801-08-08	.Fitting, 90 Elbow 8MB x 8MFF	1
7	25.FF6801-06-08	.Fitting, 90 Elbow 06MFF x 08MB	1
8	99.E0099	.Nut, "U" 5/16-18 Extruded	3
9	MA-1495	.Spacer, Hose Clamp	1
10	44.0400	.Clamp, Hyd Hose 21.3mm ID 2 Cavity (Set of 2)	3
11	44.0249	.Cover Plate, Group 3D (2 Cavity)	3
12	90.0520	.Bolt, 5/16-18 USS x 2-1/2	3
13	25.FF6801-08-10	.Fitting, 90 Elbow 08MFF x 10MB	1
14	25.FF6803-6-6-8	.Fitting, M Tee 06MFF x 06MFF x 08MB	1
15	06.0050-7IN	.Trim, Trim Loc 1/2 x 3/16 x 7"	1
16	20.0357	.Hose, 3/8x180.00 SAE 100R19AR	1
17	20.0358	.Hose, 1/2x177.00 SAE 100R19AR	1

PARTS

ILLUSTRATED DRAWING Outer Arm Extension Cylinder

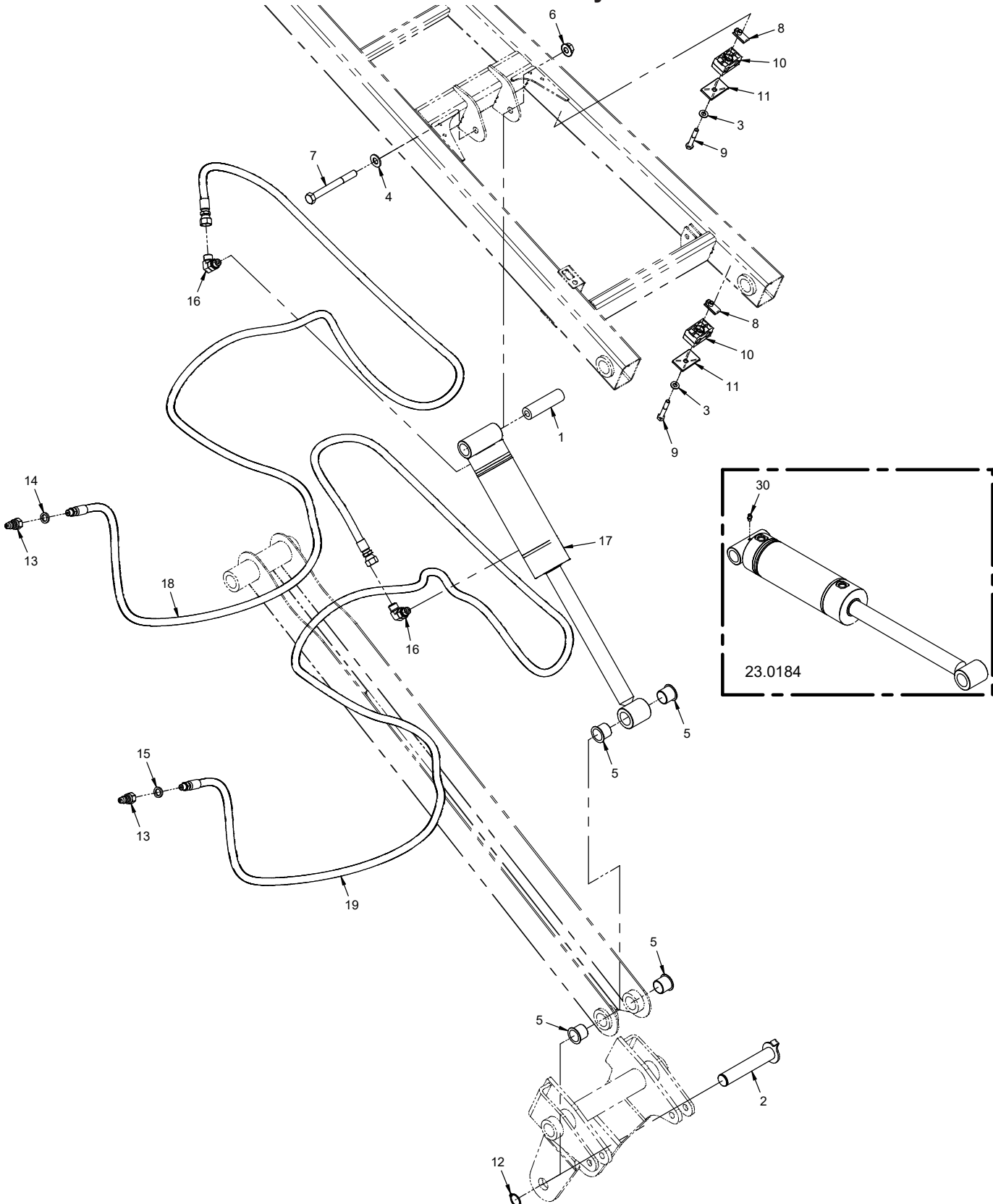

PARTS

Outer Arm Extension Cylinder

REF.	PART NO.	DESCRIPTION	QTY.
1	MA-1520	.Bushing, .510 ID x 1 OD x 3.625L	1
2	MA-6008	.Pin, Linkage Pivot Lower	1
3	95.05	.Washer, Flat 5/16 SAE	2
4	95.08	.Washer, Flat 1/2 SAE	1
5	85.B0102	.Bushing, 1.000 ID x 1.125 OD x 1 L	4
6	99.E0103	.Nut, Locking Flange 1/2-13	1
7	90.0838	.Bolt, 1/2-13 USS x 4-3/4	1
8	99.E0099	.Nut, "U" 5/16-18 Extruded	2
9	90.0516	.Bolt, 5/16-18 USS x 2	2
10	44.0256	.Clamp, Hyd Hose 12.7mm ID 2 Cavity (Set of 2)	2
11	44.0229	.Cover Plate, Group 2D (2 Cavity)	2
12	04.0016	.Snap Ring, Ext.1 Shft .042 Thk	1
13	23.0104	.Coupler, Quick Male 1/4	2
14	05.0156	.Washer, .544ID x .817 x 14 Nat	1
15	05.0157	.Washer, .544ID x .817 x 14 Blk	1
16	25.FF6801-06-06	.Fitting, 90 Elbow - 6MFF x 6MB	2
17	23.0184	.Cylinder, 2-3/4" x 6"	1
18	20.0349	.Hose, 1/4x132.00 SAE 100R17AR	1
19	20.0350	.Hose, 1/4x136.00 SAE 100R17AR	1
30	29.GF0001	.Grease Ftg, 1/4 SAE ST	1

PARTS

ILLUSTRATED DRAWING Boom Control Valve & Indicator Light

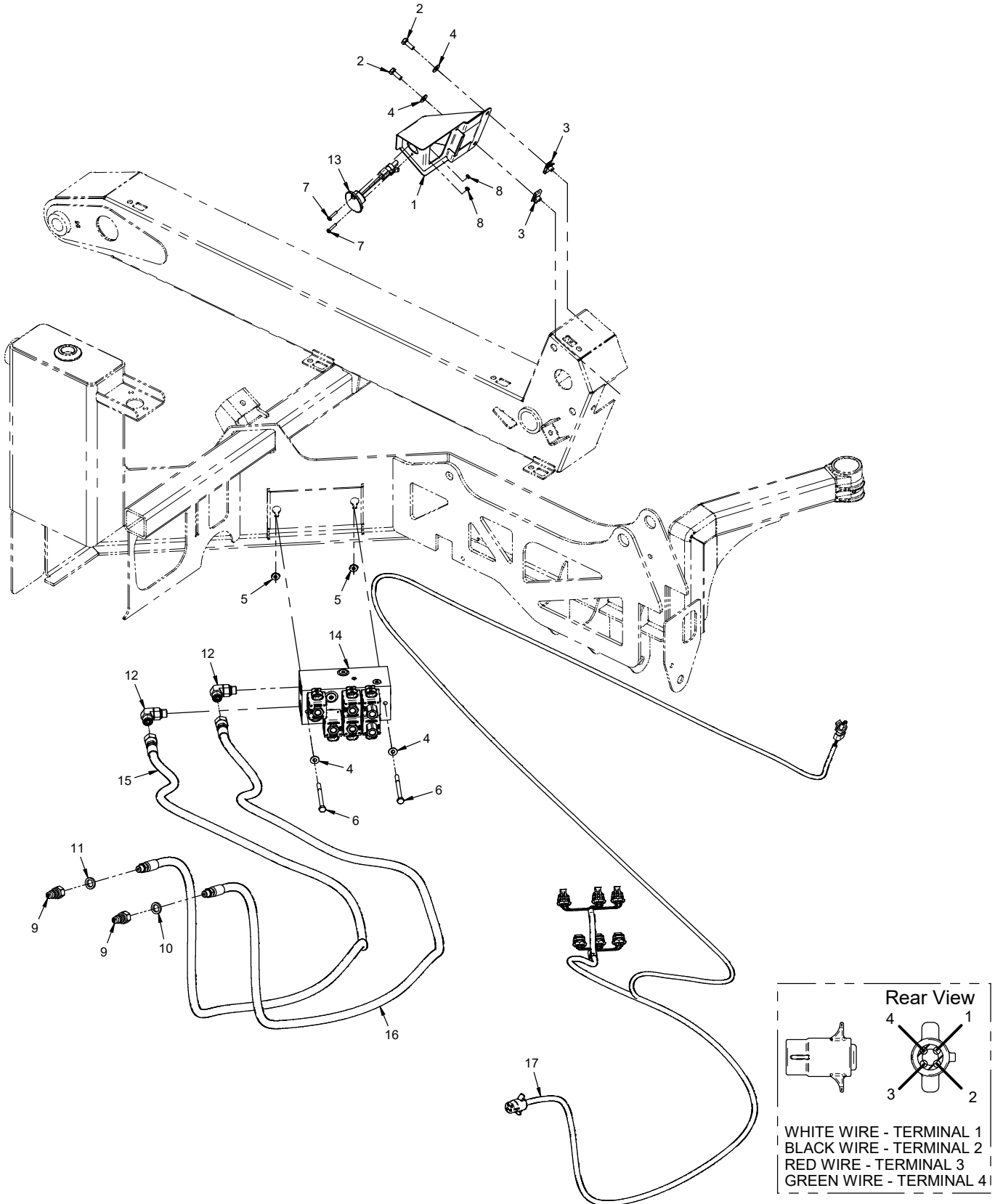

PARTS

Boom Control Valve & Indicator Light

REF.	PART NO.	DESCRIPTION	QTY.
1	MA-6017	.Mount, Indicator Light	1
2	90.0406	.Bolt, 1/4-20 USS x 3/4	2
3	99.E0046	.Nut, "U" 1/4-20 Extruded	2
4	95.04	.Washer, Flat 1/4 SAE	4
5	99.SF04	.Nut, SRF 1/4-20 USS	2
6	90.0424	.Bolt, 1/4-20 USS x 3	2
7	99.K0060	.Machine Screw, #6-32 X 3/4	2
8	99.E0085	.Locknut, Nylon #6-32	2
9	23.0104	.Coupler, Quick Male 1/4	2
10	05.0116	.Washer, .544 ID x .817 x .14 Red	1
11	05.0117	.Washer, .544 ID x .817 x .14 Yel	1
12	25.FF6801-06-06	.Fitting, 90 Elbow - 6MFF x 6MB	2
13	33.0061	.Light, Marker Red Oval	1
14	23.0183	.Valve, Boom Mower Control	1
15	20.0348	.Hose, 1/4x72.00 SAE 100R17AR	1
16	20.0348	.Hose, 1/4x72.00 SAE 100R17AR	1
17	32.0197	.Harness, Wire MA Solenoids	1

PARTS

ILLUSTRATED DRAWING Boom Control Valve Shields

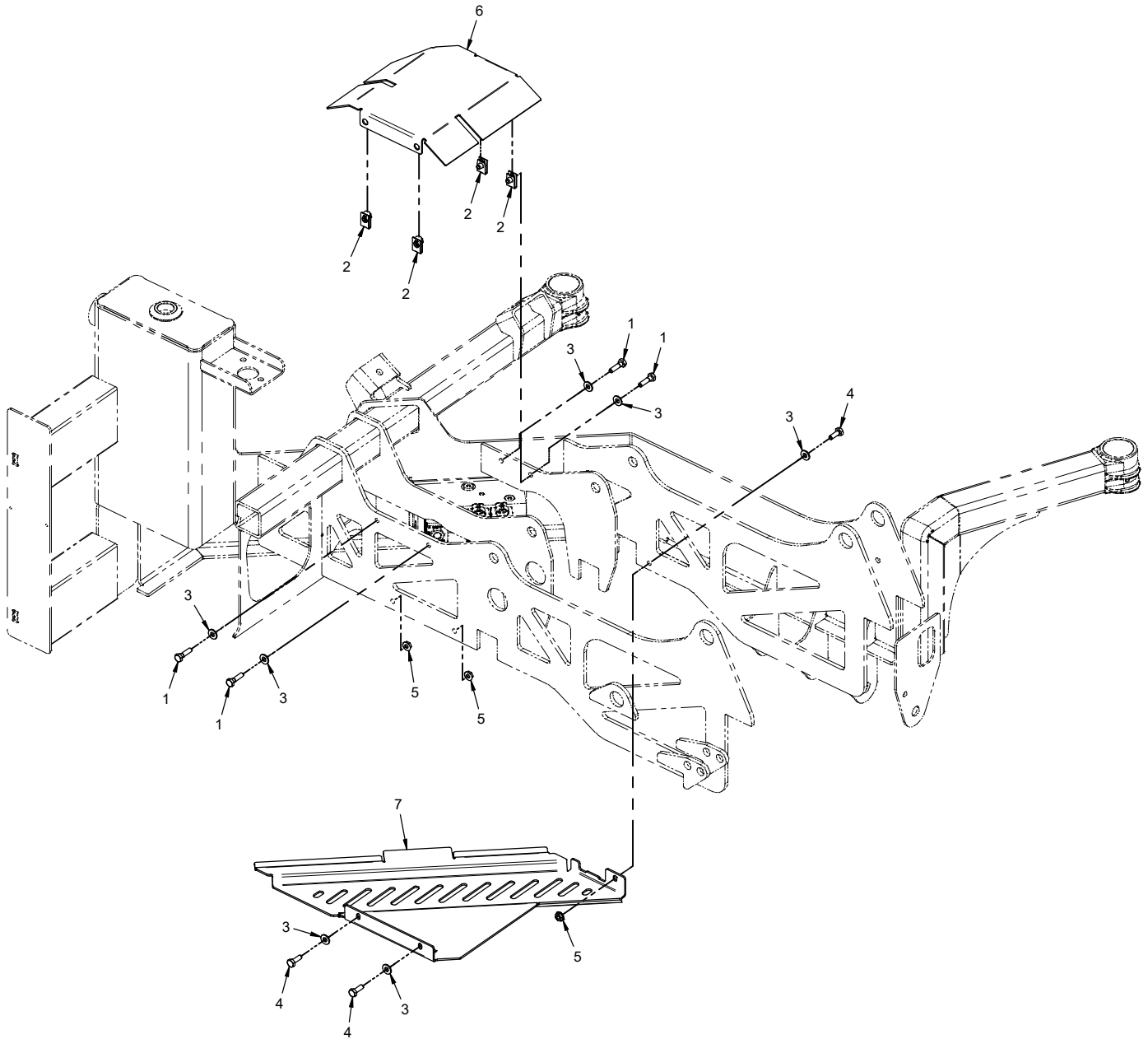

PARTS

Boom Control Valve Shields

REF.	PART NO.	DESCRIPTION	QTY.
1	90.0408	.Bolt, 1/4-20 USS x 1	4
2	99.E0046	.Nut, "U" 1/4-20 Extruded	4
3	95.04	.Washer, Flat 1/4 SAE	7
4	90.0406	.Bolt, 1/4-20 USS x 3/4"	3
5	99.SF04	.Nut, SRF 1/4-20 USS	3
6	MA-1525	.Cover, Valve Block Top	1
7	MA-1526	.Cover, Valve Block Bottom	1

PARTS

ILLUSTRATED DRAWING Main Arm Rotation Cylinders

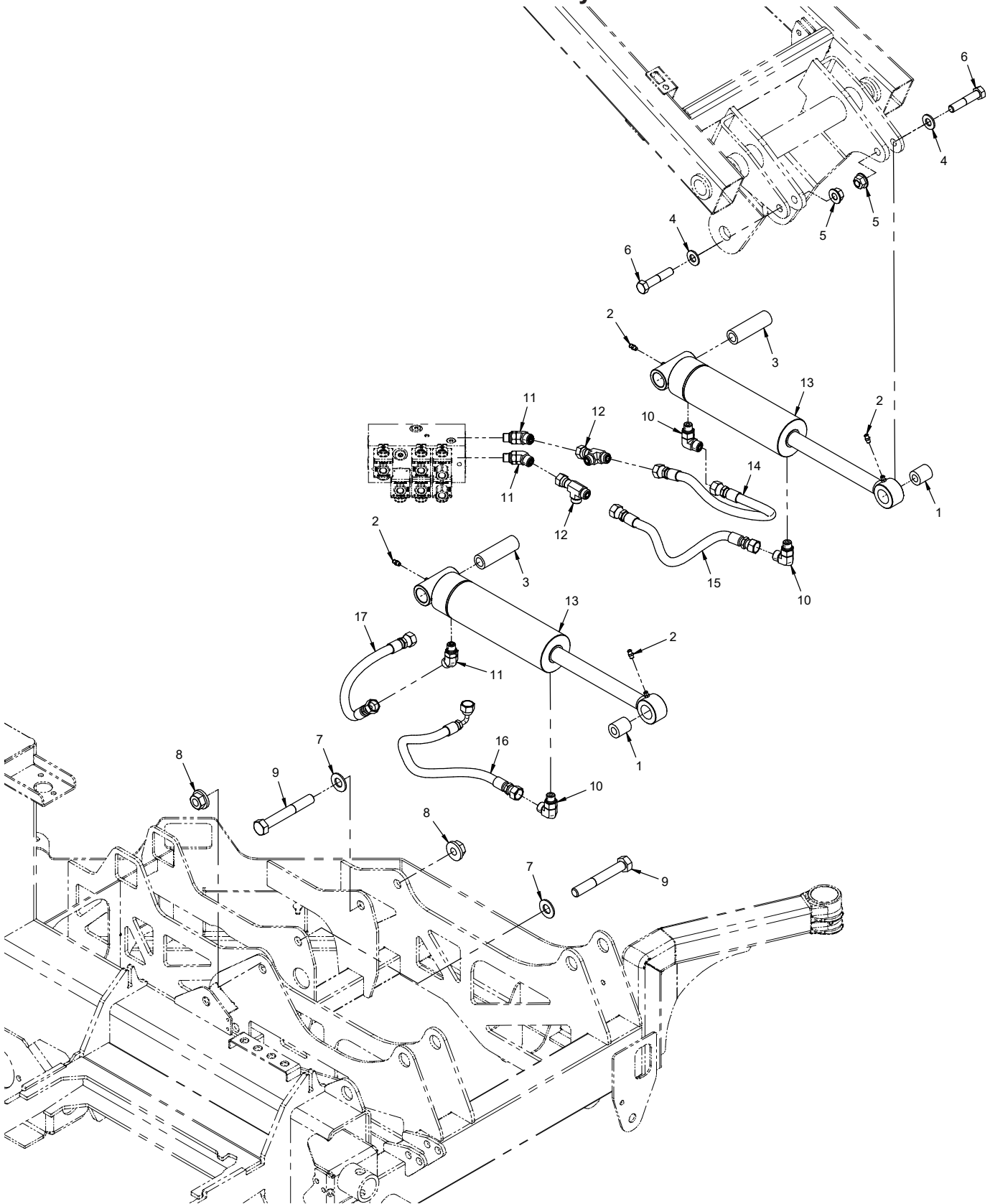

PARTS

Main Arm Rotation Cylinders

REF.	PART NO.	DESCRIPTION	QTY.
1	64.1712	.Bushing, Steel .516 x 1.000	2
2	29.GF0001	.Grease Ftg, 1/4 SAE ST	4
3	MA-1209	.Bushing, Main Cylinder	2
4	95.08	.Washer, Flat 1/2 SAE	2
5	99.E0103	.Nut, Locking Flange 1/2-13	2
6	90.0820	.Bolt, 1/2-13 USS x 2-1/2	2
7	95.10	.Washer, Flat 5/8 SAE	2
8	99.E0094	.Locknut, 5/8-11 Flanged Stover	2
9	90.1036	.Bolt, 5/8-11 USS x 4-1/2	2
10	25.FF6801-06-06	.Fitting, 90 Elbow - 6MFF x 6MB	3
11	25.FF6802-06-06	.Fitting, 45 Elbow - 6MFF X 6MB	3
12	25.FF6602-6-6-6	.Fitting, Tee 6MFF x 6FFS x 6MFF	2
13	23.0182	.Cylinder, 2-3/4" x 6-1/2"	2
14	20.0351	.Hose, 1/4x20.00 SAE 100R17AR	1
15	20.0352	.Hose, 1/4x15.00 SAE 100R17AR	1
16	20.0355	.Hose, 1/4x23.00 SAE 100R17AR	1
17	20.0356	.Hose, 1/ 4x14.00 SAE 100R17AR	1

PARTS

ILLUSTRATED DRAWING Cutter Bar Rotation Cylinder & Lockout Arm

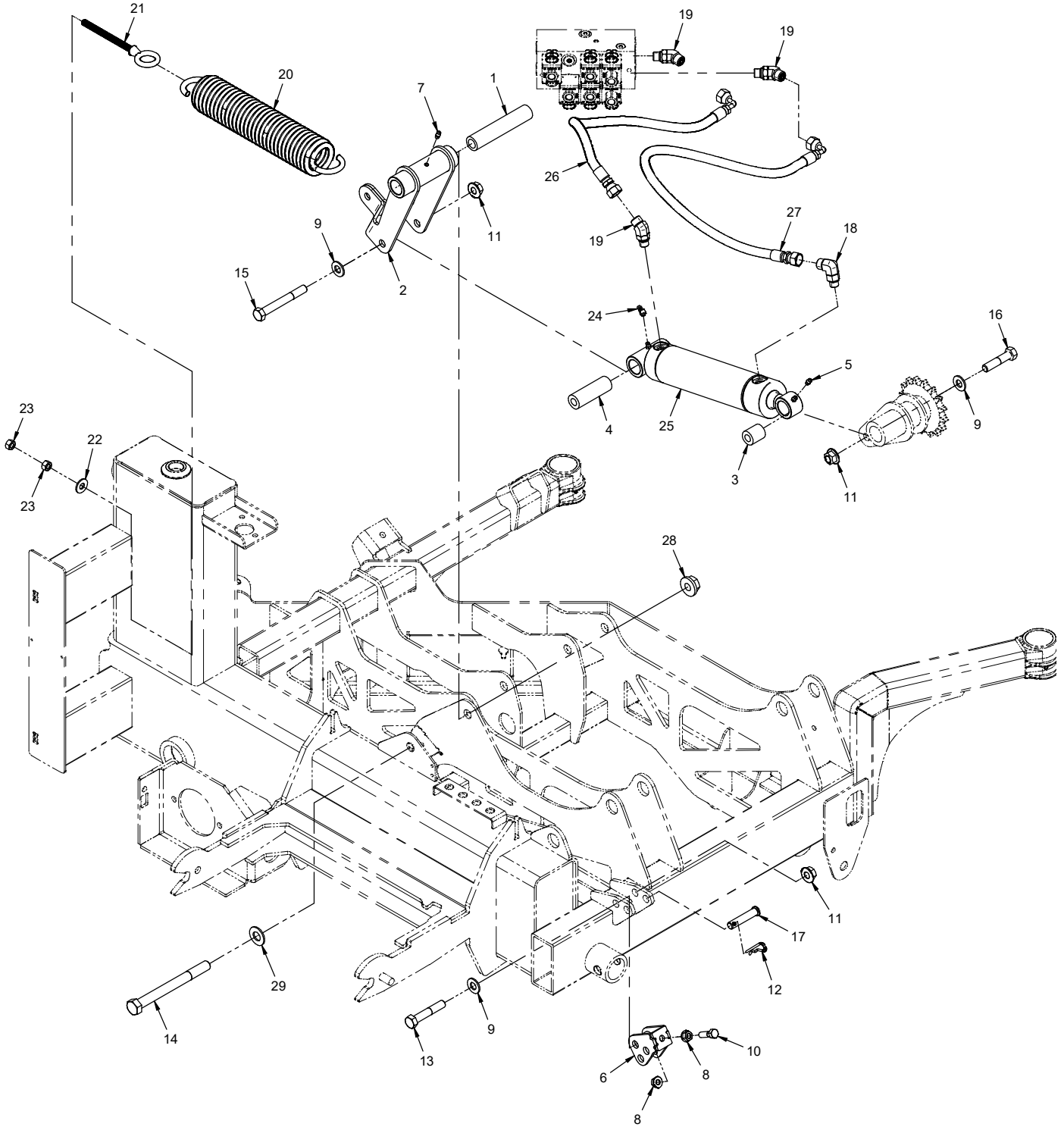

PARTS

Cutter Bar Rotation Cylinder & Lockout Arm

REF.	PART NO.	DESCRIPTION	QTY.
1	MA-1289	Bushing, Cylinder Mount Rocker	1
2	MA-6011	Rocker, Cylinder Mount	1
3	64.1712	Bushing, Steel .516 x 1.000	1
4	MA-1478	Bushing, Steel .510 x 3	1
5	29.GF0001	Grease Ftg, 1/4 SAE ST	1
6	MA-6018	Arm, Lockout	1
7	29.GF0001	Grease Ftg, 1/4 SAE ST	1
8	99.SF06	Nut, SRF 3/8-16 USS	2
9	95.08	Washer, Flat 1/2 SAE	3
10	90.0610	Bolt, 3/8-16 USS x 1-1/4	1
11	99.E0103	Nut, Locking Flange 1/2-13	3
12	02.HP0416	Hairpin, 1/8 X 2	1
13	90.0822	Bolt, 1/2-13 USS x 2-3/4	1
14	90.1052	Bolt, 5/8-11 USS x 6-1/2	1
15	90.0832	Bolt, 1/2-13 USS x 4	1
16	90.0818	Bolt, 1/2-13 USS x 2-1/4	1
17	03.0818	Clevis Pin, 1/2 X 2-1/4 ZP	1
18	25.FF6801-06-06	Fitting, 90 Elbow - 6MFF x 6MB	1
19	25.FF6802-06-06	Fitting, 45 Elbow - 6MFF X 6MB	3
20	41.0120	Spring, Ext. 2.56 OD x 13.5" Lg	1
21	99.K0164	Bolt, Eye 3/8-16 x 4-1/2	1
22	94.06	Washer, Flat 3/8 USS	1
23	92.06	Nut, 3/8-16 USS	2
24	29.GF0003	Grease Ftg, 1/4 SAE 45	1
25	23.0156	Cylinder, 2-1/4" x 7" Lift	1
26	20.0353	Hose, 1/4x27.00 SAE 100R17AR	1
27	20.0354	Hose, 1/4x37.00 SAE 100R17AR	1
28	99.E0094	Locknut, 5/8-11 Flanged Stover	1
29	95.10	Washer, Flat 5/8 SAE	1