

Parts Manual

NA 132

Drop Spreader



Revised 4/24/24
09.20088 Rev. 02



500 Venture Drive
Orrville Oh 44667
www.ventrac.com

Serial Number Description



Notes

- If any component requires replacement, use only original Ventrac replacement parts.
- When ordering new components, be sure to order all required safety decals. All current safety decals must be affixed to the replacement components prior to installation of the component.

TABLE OF CONTENTS

PARTS	PAGE 4
Main Frame & Mounts	4
Motor Mount.....	6
Front Bin Seal.....	8
Chain Drive.....	10
Rotor & Rear Roller Seal	12
Gate Panel & Control Link	14
Drive Chain Guard, Rotor Gear Guard, & Rotor Caps	16
Spreader Controller.....	18

PARTS

ILLUSTRATED DRAWING Main Frame & Mounts

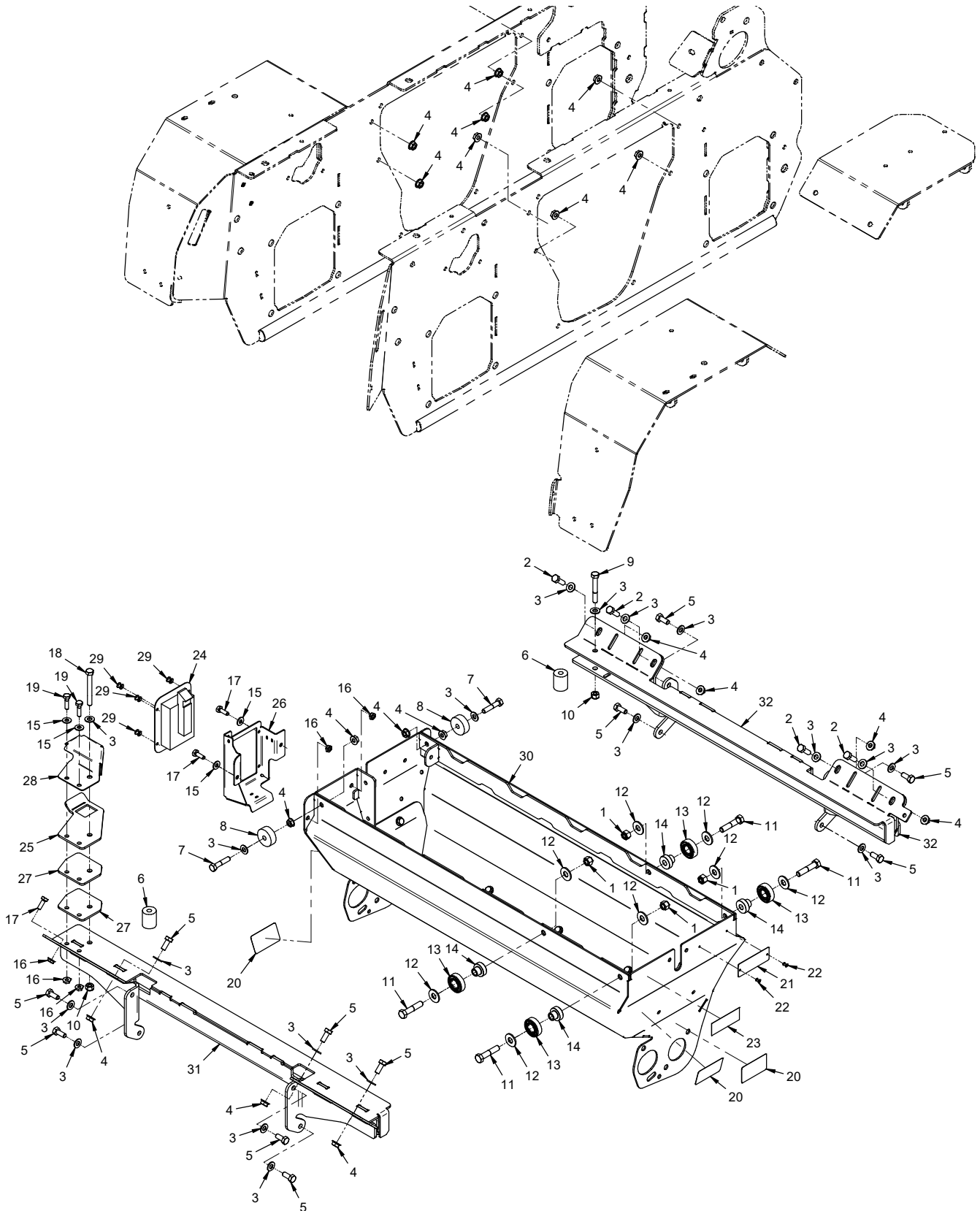

PARTS

Main Frame & Mounts

REF.	PART NO.	DESCRIPTION	QTY.
1	99.A06N-3	.Locknut, Nylon 3/8-16 SS	4
2	90.0508-3	.Bolt, 5/16-18 USS x 1 SS	4
3	95.05-3	.Washer, Flat 5/16 SAE SS	19
4	99.SF05-3	.Nut, SRF 5/16-18 USS Stainless	19
5	90.0506-3	.Bolt, 5/16-18 USS x 3/4 SS	11
6	85.B0116	.Bushing, 1OD x 5/16ID x 1-1/4W	2
7	90.0512-3	.Bolt, 5/16-18 USS x 1-1/2 SS	2
8	85.B0115	.Bushing, 1-3/8OD x 5/16ID x 1/2W	2
9	90.0518-3	.Bolt, 5/16-18 USS x 2-1/4" SS	1
10	99.A05N-3	.Locknut, Nylon 5/16-18 SS	2
11	90.0614-3	.Bolt, 3/8-16 USS x 1-3/4 SS	4
12	94.06-3	.Washer, Flat 3/8 USS Stainless	8
13	55.0123	.Bearing, Ball 15MM x 35MM, SS	4
14	85.B0114	.Bushing, Shoulder Roller Bearing NA	4
15	95.04-3	.Washer, Flat 1/4 SAE SS	4
16	99.SF04-3	.Nut, SRF 1/4-20 USS Stainless	5
17	90.0406-3	.Bolt, 1/4-20 USS x 3/4 SS	3
18	90.0522-3	.Bolt, 5/16-18 USS x 2-3/4 SS	1
19	90.0408-3	.Bolt, 1/4-20 USS x 1 SS	2
20	00.0364	.Decal, Warning Pinch Point	3
21	N/A	.Plate, Ventrac Serial Number	1
22	04.0029	.Rivet, Pop 1/8" X 1/4" SS (Serial # 0110-01305)	2
23	00.0770	.Decal, Built in the USA	1
24	47.0519	.Latch, Paddle	1
25	NA-1269	.Plate, Latch	1
26	NA-1271	.Mount, Paddle Latch	1
27	NA-1272	.Spacer, Latch Plate	2
28	NA-1273	.Cover, Latch	1
29	04.0059	.Rivet, Pop 3/16 X 1/4 SS	4
30	NA-6026	.Bin, Main	1
31	NA-6027	.Roller Rail, Rear	1
32	NA-6028	.Roller Rail, Front	1

PARTS

ILLUSTRATED DRAWING Motor Mount

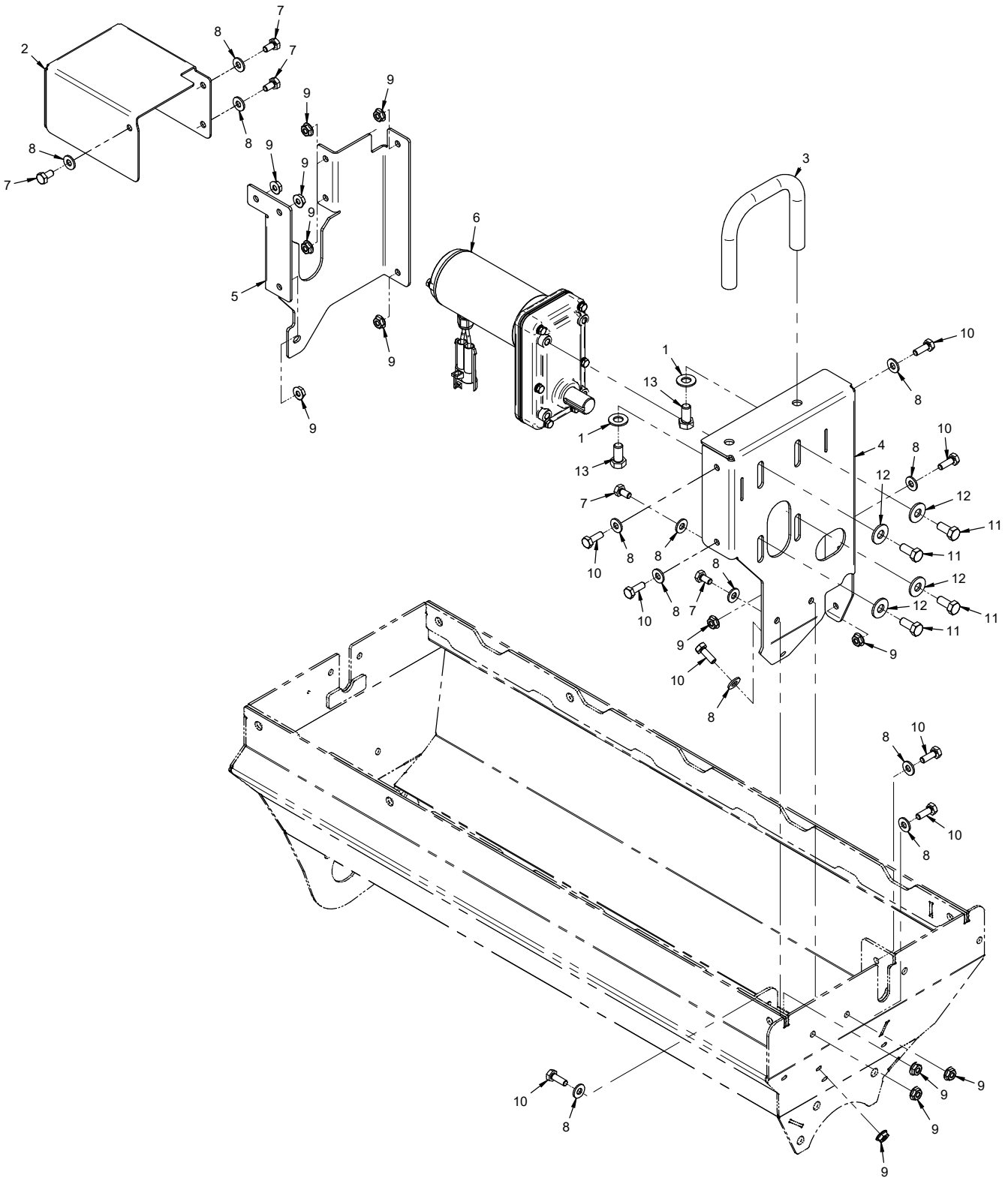

PARTS

Motor Mount

REF.	PART NO.	DESCRIPTION	QTY.
1	95.06-3	Washer, Flat 3/8 SAE SS	2
2	NA-1240	Shield, Motor	1
3	NT-1367	Grab Bar, Aux Controls	1
4	NA-1235	Motor Mount, Front	1
5	NA-1237	Motor Mount Back	1
6	37.0073	Motor, 12VDC, 40W, 12 RPM	1
7	90.0404-3	Bolt, 1/4-20 USS x 1/2 SS	5
8	95.04-3	Washer, Flat 1/4 SAE SS	13
9	99.SF04-3	Nut, SRF 1/4-20 USS Stainless	13
10	90.0406-3	Bolt, 1/4-20 USS x 3/4 SS	8
11	90.0506	Bolt, 5/16-18 USS x 3/4"	4
12	94.05	Washer, Flat 5/16 USS	4
13	90.0606-3	Bolt, 3/8-16 USS x 3/4 SS	2

PARTS

ILLUSTRATED DRAWING Front Bin Seal

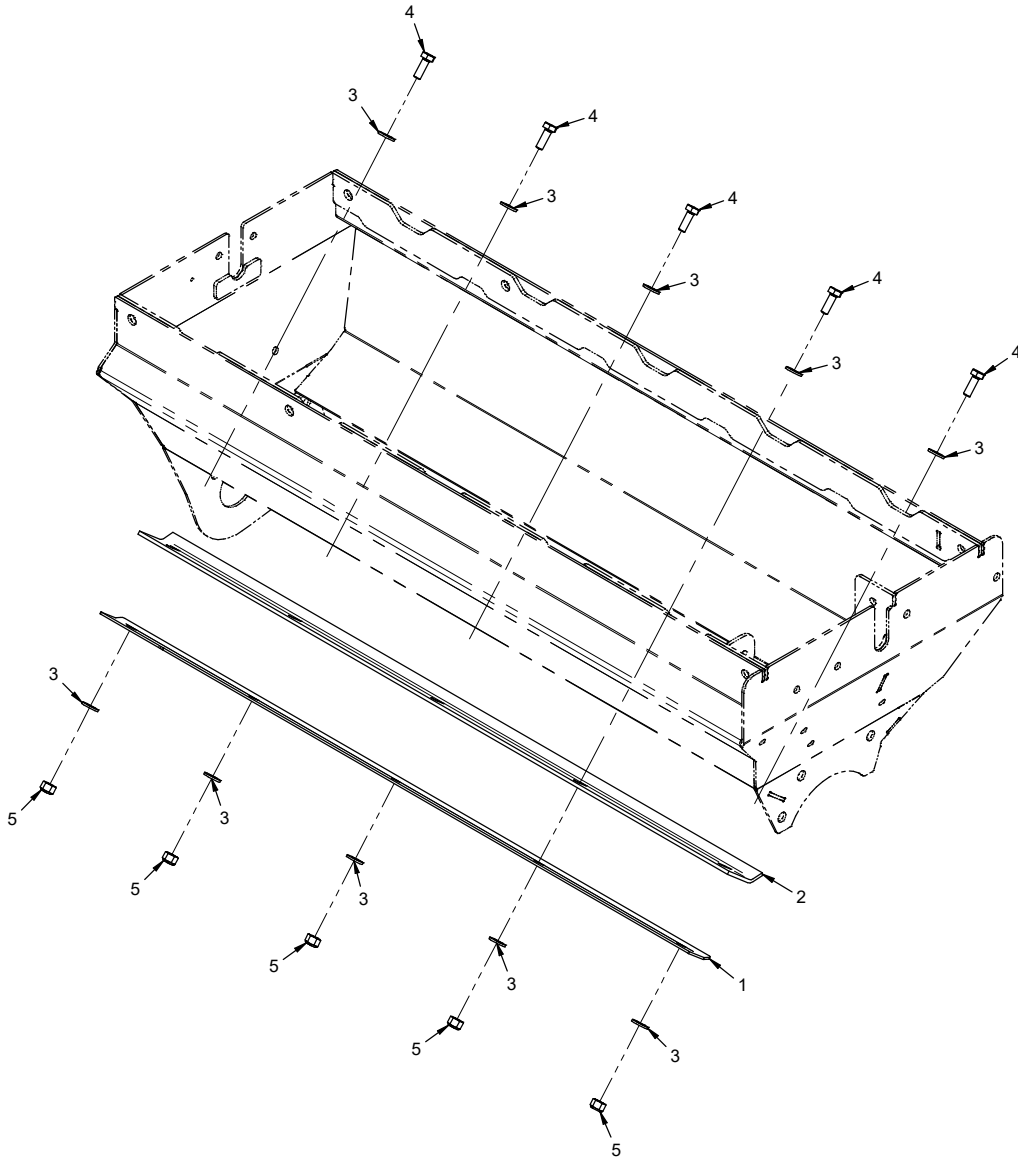

PARTS

Front Bin Seal

REF.	PART NO.	DESCRIPTION	QTY.
1	NA-1260	Clamp, Bin Front Belting Seal	1
2	NA-1908	Seal, Bin Front Belting	1
3	95.04-3	Washer, Flat 1/4 SAE SS	10
4	90.0406-3	Bolt, 1/4-20 USS x 3/4 SS	5
5	99.A04N-3	Locknut, Nylon 1/4-20 USS SS	5

PARTS

ILLUSTRATED DRAWING Chain Drive

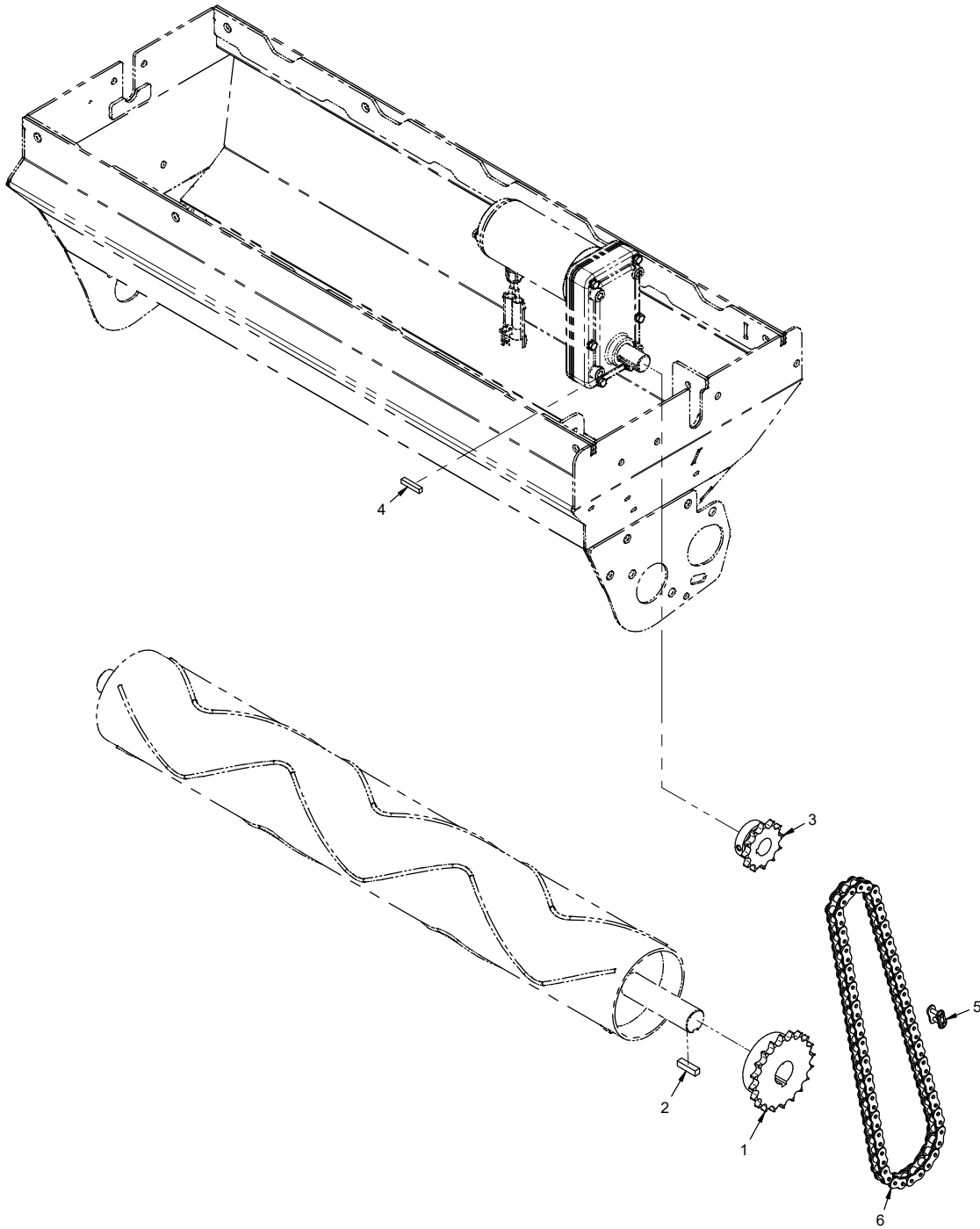

PARTS

Chain Drive

REF.	PART NO.	DESCRIPTION	QTY.
1	83.402016SS	Sprocket, #40 20-T 1" Bore, SS.	1
2	85.K0408-3	Key, 1/4 x 1 316SS	1
3	83.401212SS	Sprocket, #40 12-T 3/4" Bore, SS.	1
4	85.K0308-3	Key, 3/16 X 1 SS	1
5	81.0056-1	Link, Conn. #40 SS.	1
6	81.0191	Chain, Roller #40 x 35" SS	1

PARTS

ILLUSTRATED DRAWING Rotor & Rear Roller Seal

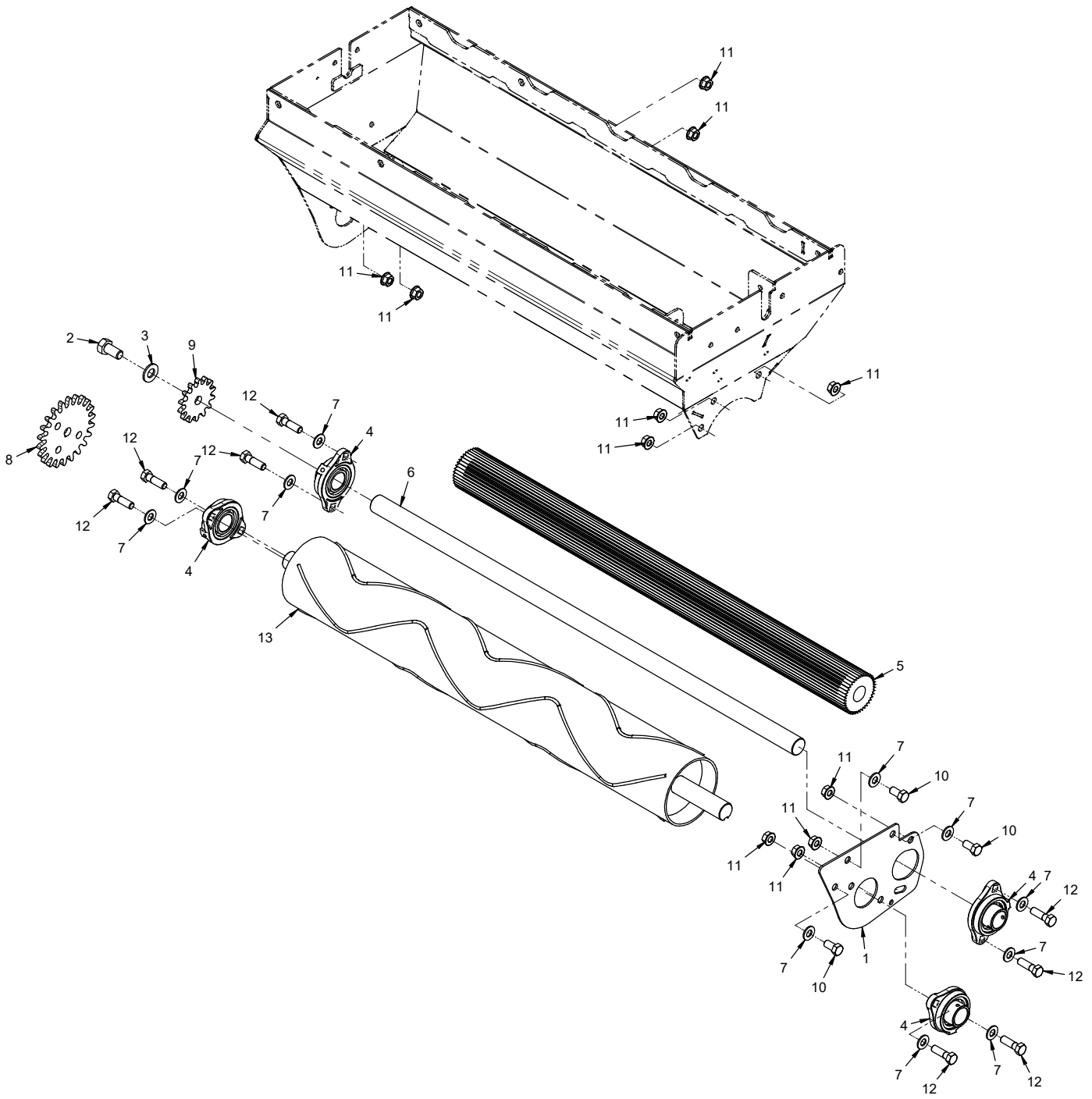

PARTS

Rotor & Rear Roller Seal

REF.	PART NO.	DESCRIPTION	QTY.
1	NA-1101	Bracket, Lower Bin	1
2	90.0808-3	Bolt, 1/2-13 USS x 1 SS	1
3	95.08-3	Washer, Flat 1/2 SAE SS	1
4	55.FB16016-3	Bearing, Flange Block 1" ZP	4
5	44.0396	Seal, Bin Rear Tube	1
6	NA-1905	Shaft, Tube Seal	1
7	95.06-3	Washer, Flat 3/8 SAE SS	11
8	NA-1138	Gear, Spreader Rotor	1
9	NA-1137	Gear, Spreader Seal	1
10	90.0606-3	Bolt, 3/8-16 USS x 3/4SS	3
11	99.SF06-3	Nut, SRF 3/8-16 USS Stainless	11
12	90.0610-3	Bolt, 3/8-16 USS x 1-1/4 SS	8
13	NA-6901	Rotor, NA130 Spreader	1

PARTS

ILLUSTRATED DRAWING Gate Panel & Control Link

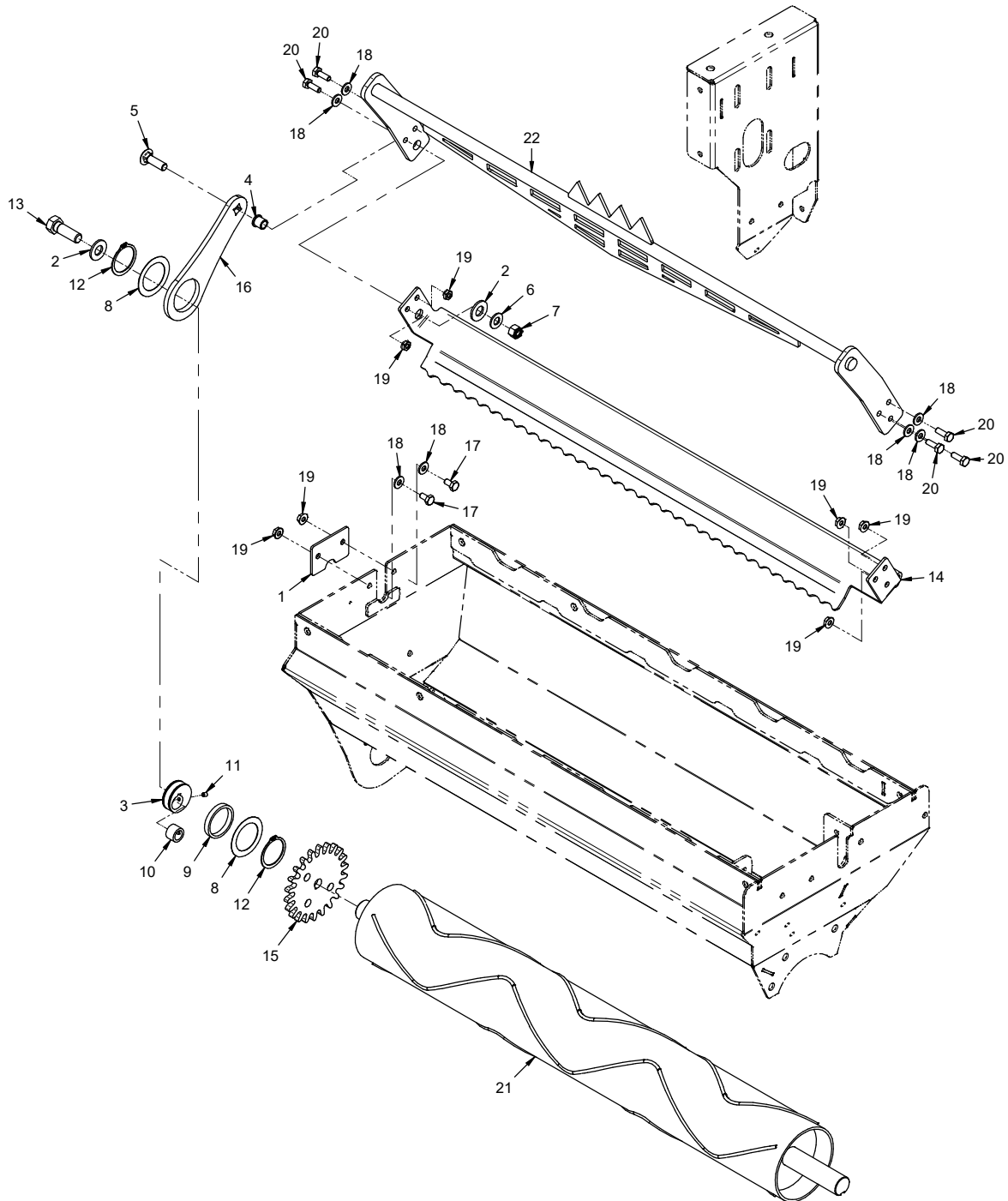

PARTS

Gate Panel & Control Link

REF.	PART NO.	DESCRIPTION	QTY.
1	NA-1254	Bracket, Gate Rod Support	1
2	95.08-3	Washer, Flat 1/2 SAE SS	2
3	42.0568	Material Spec Update	1
4	85.B0068	Bushing, 3/8 X 1/2 OD X 1/2 LG	1
5	97.0610-3	Bolt, Carriage 3/8-16 X 1-1/4 SS	1
6	95.06-3	Washer, Flat 3/8 SAE SS	1
7	99.A06N-3	Locknut, Nylon 3/8-16 SS	1
8	99.B0112	Shim, 1.5ID x 2.13 OD .020T SS	2
9	85.B0092	Bushing, Bronze Sleeve	1
10	NA-1988	Bushing, .510 ID X .74OD	1
11	85.SS26	Set Screw, 10-32 x 1/4 SS	1
12	04.0034	Snap Ring, Ext 1.387 x .05 THK	2
13	90.0812-3	Bolt, 1/2-13 USS x 1-1/2 SS	1
14	NA-1250	Panel, Gate	1
15	NA-1138	Gear, Spreader Rotor	1
16	NA-1118	Link, Gate Control	1
17	90.0404-3	Bolt, 1/4-20 USS x 1/2 SS	2
18	95.04-3	Washer, Flat 1/4 SAE SS	7
19	99.SF04-3	Nut, SRF 1/4-20 USS Stainless	7
20	90.0406-3	Bolt, 1/4-20 USS x 3/4 SS	5
21	NA-6901	Rotor, NA130 Spreader	1
22	NA-6036	Arm, Gate Slide	1

PARTS

ILLUSTRATED DRAWING Drive Chain Guard, Rotor Gear Guard, & Rotor Caps

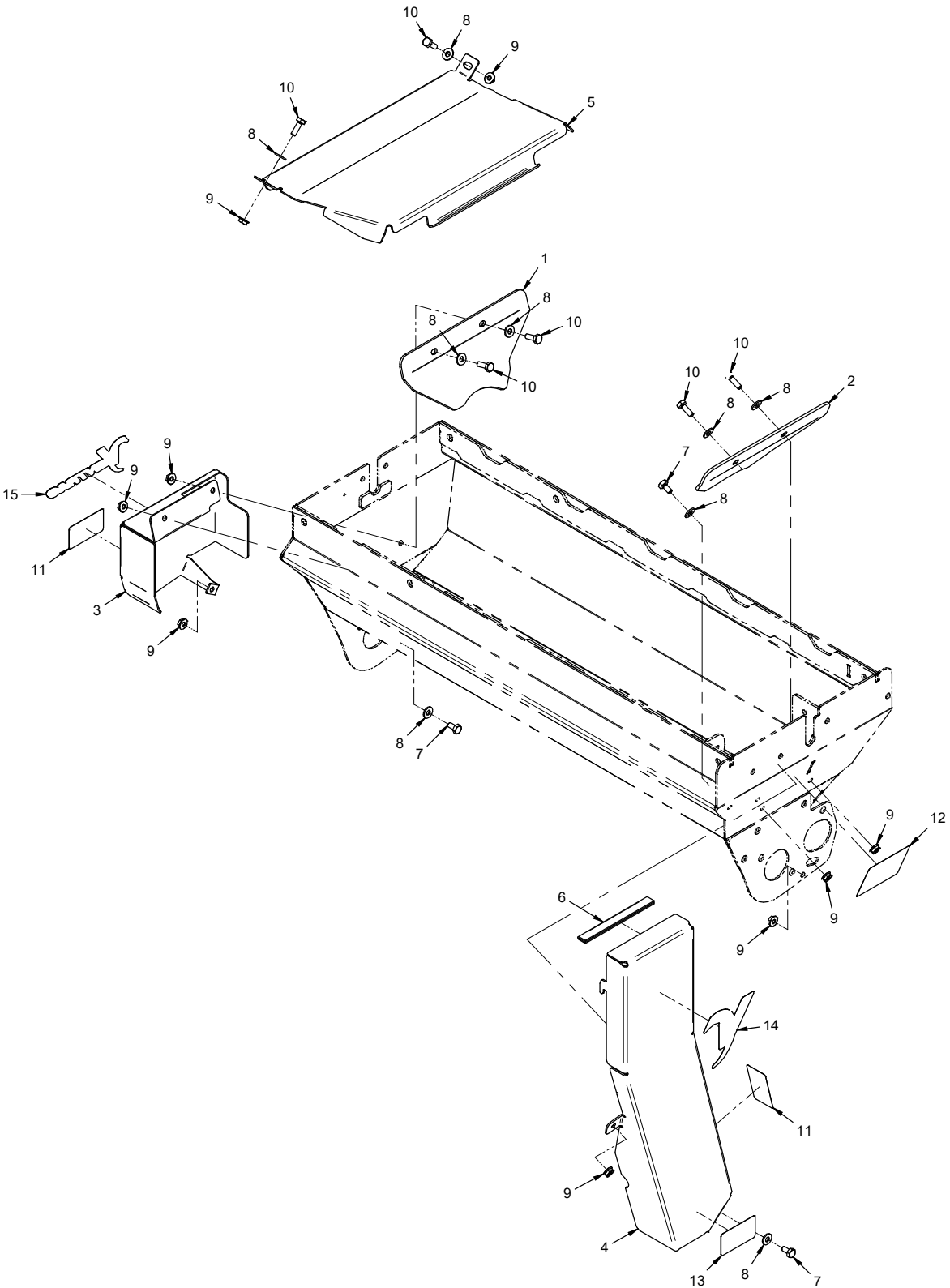

PARTS

Drive Chain Guard, Rotor Gear Guard, & Rotor Caps

REF.	PART NO.	DESCRIPTION	QTY.
1	NA-1181	Bracket, Rotor Cap Right	1
2	NA-1183	Bracket, Rotor Cap Left	1
3	NA-1210	Shield, Rotor Gear	1
4	NA-1231	Cover, Drive Chain	1
5	NA-1264	Cover, Hopper Right	1
6	06.0042-5IN	Trim, Trim Loc 1/2 x 1/16 x 5"	1
7	90.0404-3	Bolt, 1/4-20 USS x 1/2 SS	3
8	95.04-3	Washer, Flat 1/4 SAE SS	9
9	99.SF04-3	Nut, SRF 1/4-20 USS Stainless	9
10	90.0406-3	Bolt, 1/4-20 USS x 3/4 SS	6
11	00.0364	Decal, Warning Pinch Point	2
12	00.0625	Decal, Shield Missing	1
13	00.0631	Decal, Finger/Hand Entanglement	1
14	00.0192	Decal, V-Decal Die Cut Blue	1
15	00.0382	Decal, Ventrac	1

PARTS

ILLUSTRATED DRAWING Spreader Controller

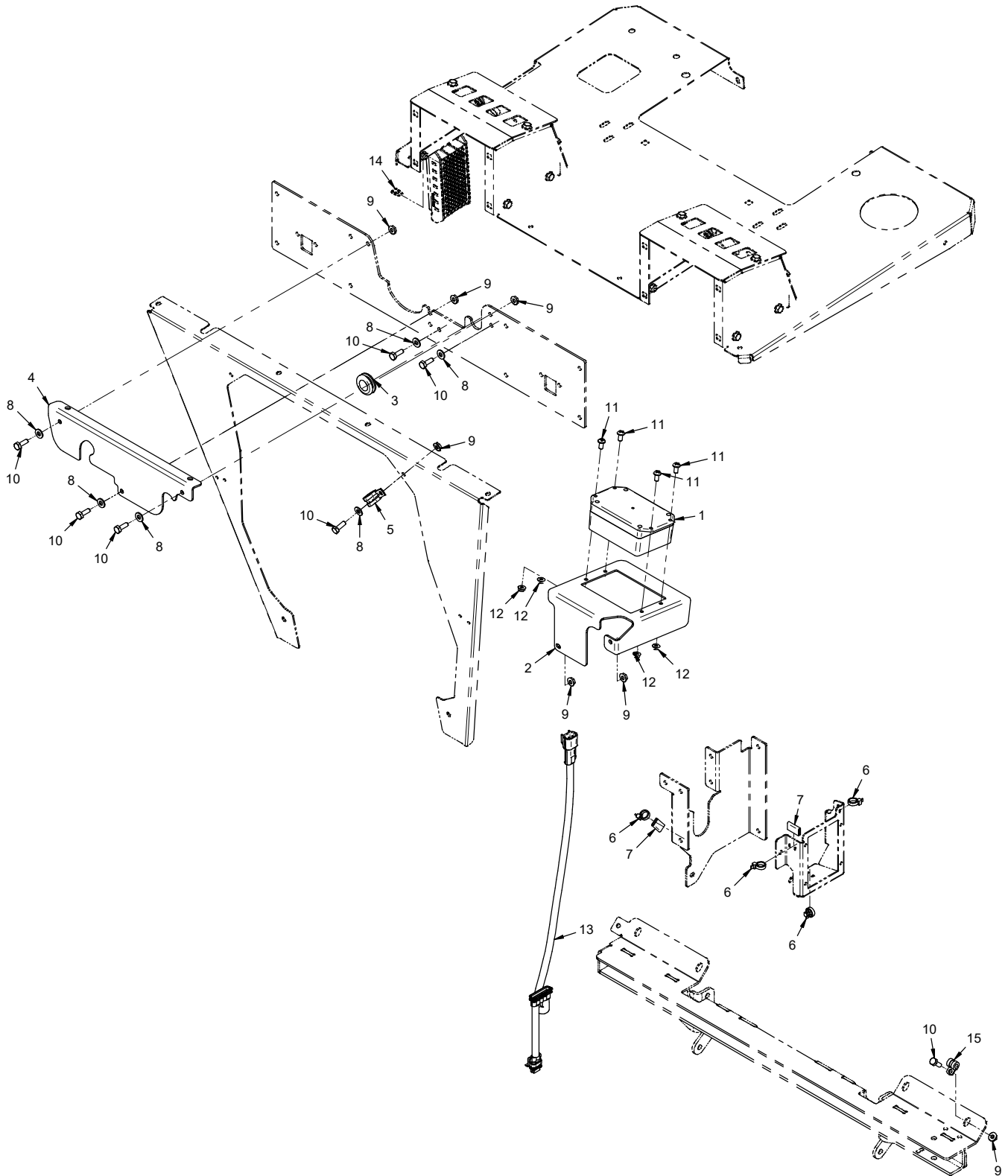

PARTS

Spreader Controller

REF.	PART NO.	DESCRIPTION	QTY.
1	35.0165	Controller, 12V DC, Potted	1
2	NA-1226	Mount, Controller	1
3	05.0045	Grommet, 3/4Id,1 3/8Od,1/2Thk.	1
4	NT-1556	Plate, Dash Front Cover	1
5	11.0076	Clamp, Cushioned 1/2" SS	1
6	30.0037	Tyton Tie, #50 .18 x 8 Black	4
7	06.0042-1IN	Trim, Trim Loc 1/2 X 1/16 x 1" L	2
8	95.04-3	Washer, Flat 1/4 SAE SS	6
9	99.SF04-3	Nut, SRF 1/4-20 USS Stainless	7
10	90.0406-3	Bolt, 1/4-20 USS x 3/4 SS	7
11	99.K0165	Machine Screw, #10-32 x 1/2 SS	4
12	99.E0125	Nut, SRF #10-32 Stainless	4
13	32.0202	Harness, Wire NA130 Drop Spreader	1
14	30.0333	Fuse, 10 Amp Mini Red	1
15	11.0090	Clamp, Cushioned 3/8" SS	1